

APPENDIX A: EXAMPLE 1970 AND 2011 FOCUS AREA AERIAL  
IMAGERY

APPENDIX B: DATA-COLLECTION STATION METADATA EXAMPLES

APPENDIX C: DATA-COLLECTION STATION PROGRAMS AND WIRING  
DIAGRAM EXAMPLES

APPENDIX D: SELECTED FOCUS AREA TIME-LAPSE PHOTO  
EXAMPLES

APPENDIX E: LEVEL-LOOP SURVEY AND SURVEY CONTROL POINTS  
EXAMPLES

**Susitna-Watana Hydroelectric Project  
(FERC No. 14241)**

**Groundwater Study (7.5)**

**Appendix A  
Example 1970 and 2011 Focus Area Aerial Imagery**

**Initial Study Report**

Prepared for

Alaska Energy Authority



**SUSITNA-WATANA HYDRO**

*Clean, reliable energy for the next 100 years.*

Prepared by

Geo-Watersheds Scientific

February 2014 Draft

## APPENDIX A: EXAMPLE 1970 AND 2011 FOCUS AREA AERIAL IMAGERY

The selected images in this appendix include paired aerial images from the 1970s<sup>1</sup> and 2011, an approximate span of 40 years. The selected aerial images are provided in order to compare these Focus Areas over a span of nearly 40 years in order to inform study objectives.

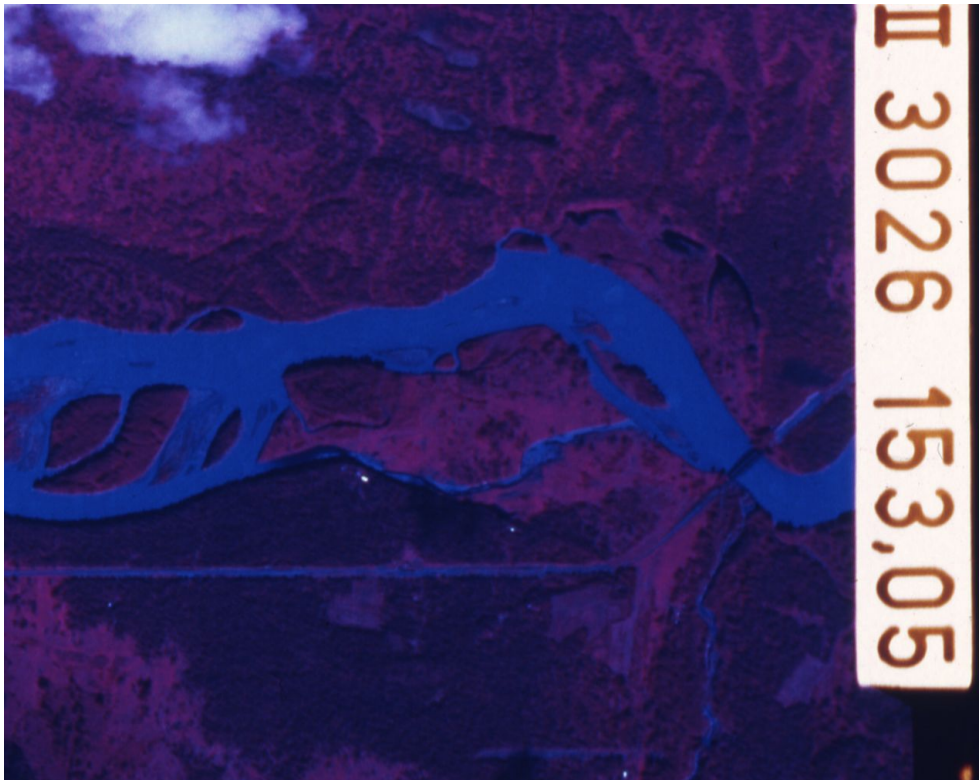
<sup>1</sup>The date of the 1970s images is under investigation.

**Table A-1.** This table lists example paired aerial images from the 1970s<sup>1</sup> and 2011, a comparison of images spanning approximately 40 years. Following the table, example images are provided in downstream Focus Area order.

<b>Stations Comparing 1970s and 2011 Aerial Images</b>
FA-138 (Gold Creek)
FA-128 (Slough 8A) Large-scale images
FA-128 (Slough 8A) Small-scale images
FA-113 (Oxbow 1)
FA-104 (Whiskers Slough)

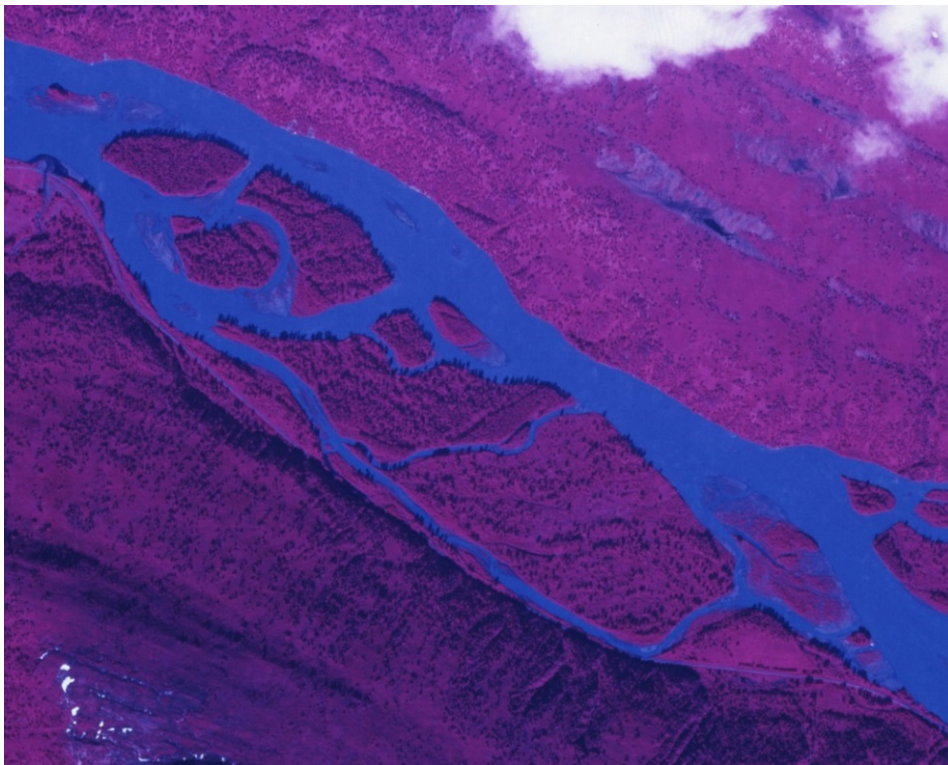
<sup>1</sup>The exact date of the 1970s images is under investigation.





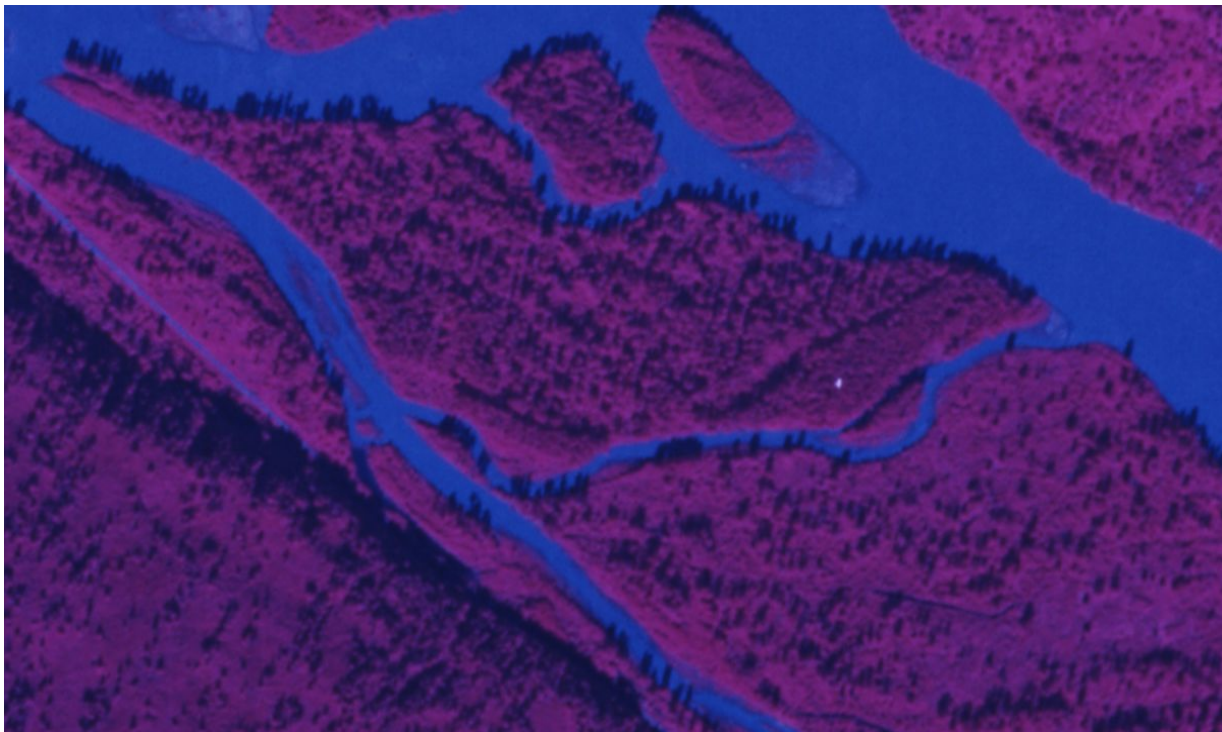
**Figure A-1. These aerial images provide a point of comparison between FA-138 (Gold Creek) in the 1970s versus 2011. The top image depicts FA-138 (Gold Creek) in 2011, and the bottom image depicts this FA in the 1970s. The images will help improve the understanding of the riparian vegetation changes, geomorphology changes and potential changes to the groundwater/surface-water relationships.**





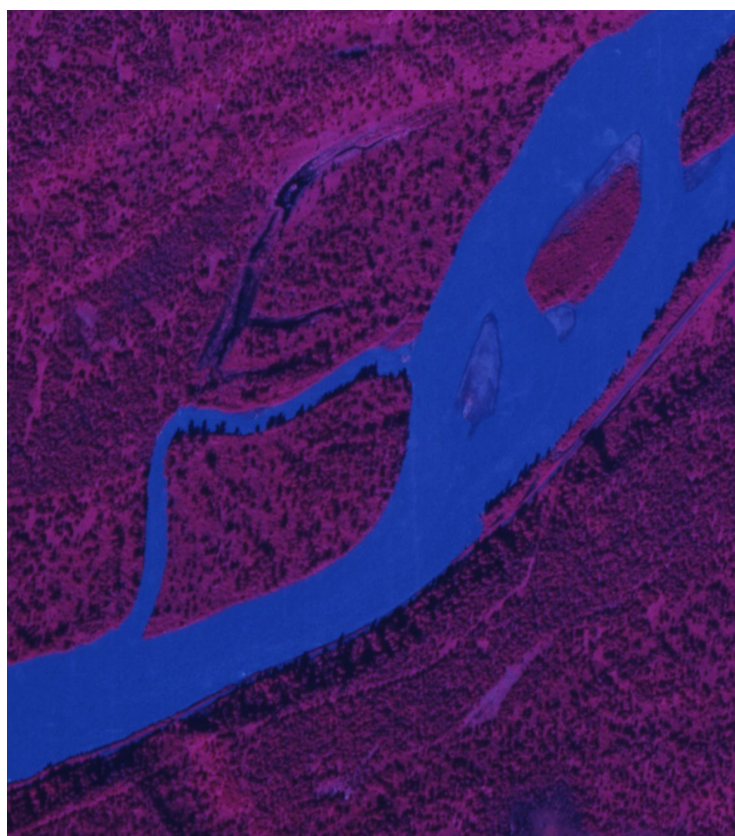
**Figure A-2.** These aerial images provide a point of comparison between FA-128 (Slough 8A) in the 1970s versus 2011 from a large-scale perspective. The top image depicts FA-128 (Slough 8A) in 2011, and the bottom image depicts this FA in the 1970s. The images will help improve the understanding of the riparian vegetation changes, geomorphology changes and potential changes to the groundwater/surface-water relationships.



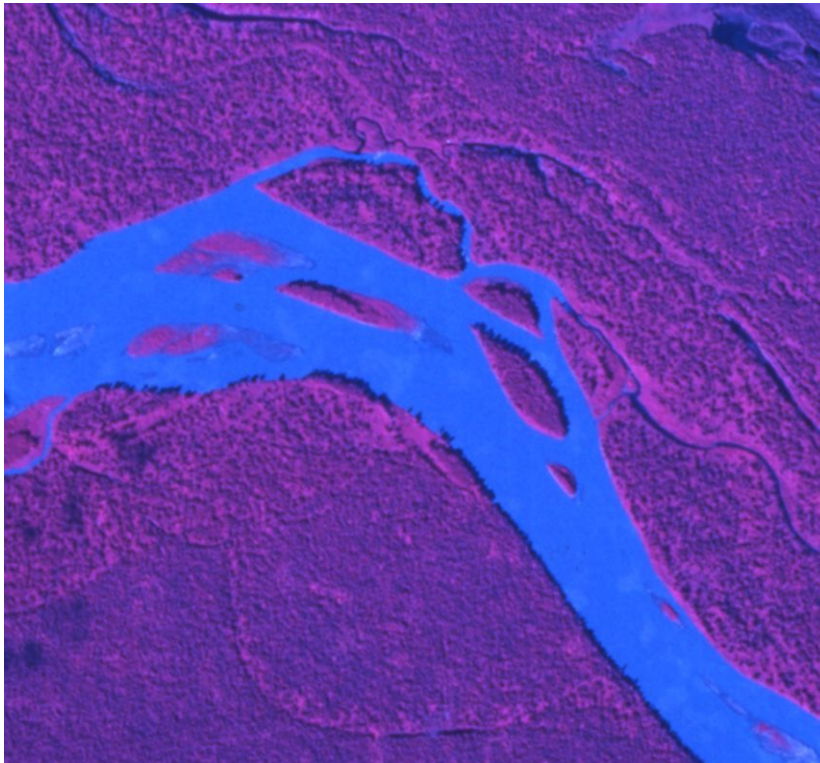


**Figure A-3.** These aerial images provide a point of comparison between FA-128 (Slough 8A) in the 1970s versus 2011 from a small-scale perspective. The top image depicts FA-128 (Slough 8A) in 2011, and the bottom image depicts this FA in the 1970s. The images will help improve the understanding of the riparian vegetation changes, geomorphology changes and potential changes to the groundwater/surface-water relationships.





**Figure A-4.** These aerial images provide a point of comparison between FA-113 (Oxbow 1) in the 1970s versus 2011. The top image depicts FA-113 (Oxbow 1) in 2011, and the bottom image depicts this FA in the 1970s. The images will help improve the understanding of the riparian vegetation changes, geomorphology changes and potential changes to the groundwater/surface-water relationships.



**Figure A-5. These aerial images provide a point of comparison between FA-104 (Whiskers Slough) in the 1970s versus 2011. The top image depicts FA-104 (Whiskers Slough) in 2011, and the bottom image depicts this FA in the 1970s. The images will help improve the understanding of the riparian vegetation changes, geomorphology changes and potential changes to the groundwater/surface-water relationships.**

**Susitna-Watana Hydroelectric Project  
(FERC No. 14241)**

**Groundwater Study (7.5)**

**Appendix B  
Groundwater Study Data-Collection Station Metadata  
Examples**

**Initial Study Report**

Prepared for

Alaska Energy Authority



**SUSITNA-WATANA HYDRO**

*Clean, reliable energy for the next 100 years.*

Prepared by

Geo-Watersheds Scientific

February 2014 Draft

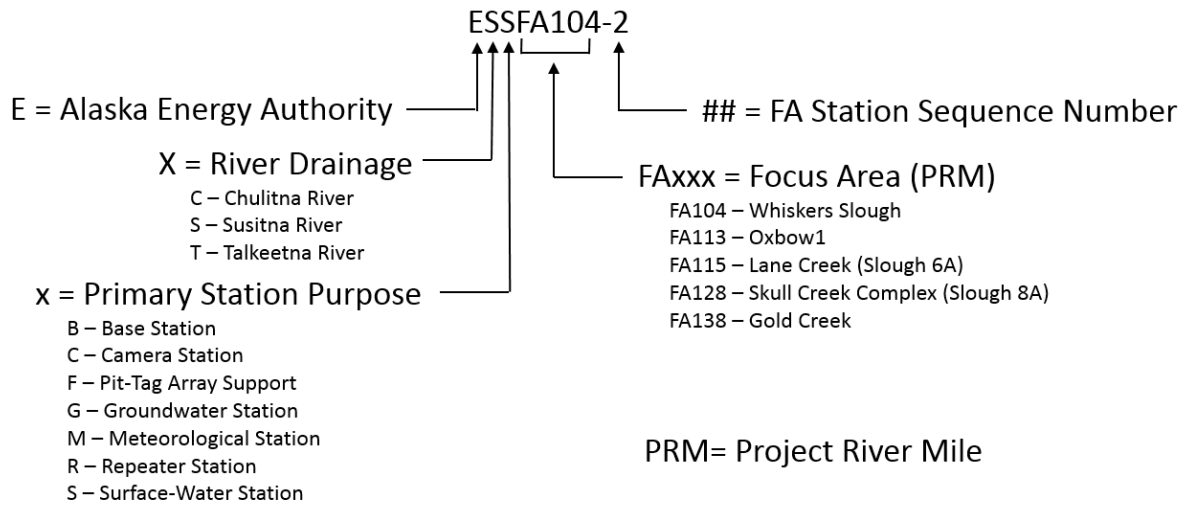
## APPENDIX B: GROUNDWATER STUDY DATA-COLLECTION STATION METADATA EXAMPLES

The Groundwater Study data-collection station measurement standards help ensure the collection of quality datasets. The examples within this appendix show the range of standard metadata that are being tracked for different types of stations. These metadata meet study objectives for a range of diverse study collection objectives for different station types: surface-water, groundwater, and meteorological primary station types. The standard data collection platform is the Campbell Scientific Inc. (CSI) CR1000 data logger. At some simpler stations, a CSI CR200X data logger is used when minimal measurements are needed. For those sites that do not require real-time reporting, an Instrumentation Northwest (INW) self-logging pressure transducer is used. There are variations within the CSI stations depending on the study analysis needs in different locations. These variations range from measuring streambed temperature profiles in lateral habitats to sap flow sensors in riparian forests. Written data standards have been established for each station type. All of these data measurement and recording standards files are found on the GINA supporting website for the project. The data can be accessed at <http://gis.suhydro.org/reports/isr>.

**Table B-1. This table lists representative station types with corresponding metadata for each station type. Following the table, example metadata files for surface-water, groundwater, and meteorological stations are provided.**

Focus Area	Primary Station Purpose (variation)	Representative Station
FA-128 (Slough 8A)	Surface Water (CSI CR1000)	ESSFA128-1
FA-115 (Slough 6A)	Groundwater (INW PT2X)	ESGFA115-8
FA-104 (Whiskers Slough)	Meteorological (CSI CR1000)	ESMFA104-2
FA-104 (Whiskers Slough)	Groundwater (CSI CR200X)	ESGFA104-3
FA-104 (Whiskers Slough)	Groundwater (CR1000, sap flow sensors)	ESGFA104-4
FA-104 (Whiskers Slough)	Groundwater (CSI CR1000, stream-bed profiles)	ESGFA104-10





**Figure B-1. Data collection station short name convention used for continuously monitored stations.** Most stations collect data for multiple study objectives. This allows for improved efficiency of synoptic data collection and data collection standards.

**The following describes surface-water data measurement and recording standards for FA-128 (Slough 8A) station ESSFA128-1, representative of a surface-water CSI CR1000 type station:**

### **Susitna Hydrology Project**

#### **ESSFA128-1 Focus Area Station**

#### **Data Measurement and Recording Standards**

Last Update: 06/25/2013

Last Update By: R Paetzold

### **Focus Area Station**

Data-Collection Objectives: Meteorological data to evaluate the potential for hydro-electric power generation in the Susitna River region.

Time Recording Standard: **Always** Alaska Standard Time (UTC – 9).

Datalogger Scan Interval Standard: 60 seconds.

#### Time Measurement Standards:

Hourly readings are recorded at the end of the hour; therefore, the hourly average water temperature, for example, with a 60-second scan interval and a time stamp of 14:00 is measured from 13:01 to 14:00:00. For a 60-second scan interval, the hourly average would be the average of 60 min = 60 values.

Quarter-hourly readings are recorded every fifteen minutes starting at the top of the hour.

Instantaneous readings are taken at the time specified by the time stamp.

A day begins at midnight (00:00:00) and ends at midnight (23:59:55). All daily data are from the day prior to the date of the time stamp. For example, if the time stamp reads 09/09/2007 00:00 or 09/09/2007 12:00:00 AM, the data are from 09/08/2007.

Data Retrieval Interval: Data will be retrieved hourly.

Data Reporting Interval: Hourly

### **Images**

Camera: Two CC5MPXWD digital cameras.

Memory Card: 8G Flash Memory Card

Flash Card Capacity: ~20,000 Images or over 2 years.

Lo Resolution Image Size: ~50k bytes each (640x480 resolution; Hi compression)

Hi Resolution Images Size: ~250k bytes each (1280x960 resolution; Lo compression)

Images Taken: Both on camera's internal time interval and external trigger. External trigger from datalogger control port allows for manually-initiated image.

Images Saved on Camera Memory Card: Both Hourly Hi-Resolution and Hourly Lo-Resolution

Images Saved on Datalogger: Up to the ten most recent Hourly Lo-Resolution images.

Image Trigger Interval: 60-minutes

Data Retrieval Interval: One image every hour.

Connection: Direct MD485 for two cameras

Lens Defrost: enabled as automated or manual

Remote Camera Powerup: Enabled. Allows for remote control of camera PakBus settings

Start and Stop Image Taking Times: manually adjustable for externally triggered images.

**Air Temperature**

Sensor: Triplicate YSI Series 44033 thermistors

Operating Range: -80°C to +75°C

Installation: In 6-gill radiation shield, non-aspirated.

Height: 2 meters

Output Units: k $\Omega$ , °C.

Scan Interval: 60 seconds

Output to Tables:

Hourly Atmospheric Table:

Hourly Sample Air Temperature: Recorded at the top of each hour. (three values, one for each thermistor).

Hourly Average Air Temperature: Average of the 60 one-minute readings for the previous hour. (three values, one for each thermistor).

Daily Table:

Daily Average Air Temperature: Average of all temperature readings for the previous day ending at midnight AST. (three values, one for each thermistor).

Daily Maximum Air Temperature: The highest reading from the previous day. (three values, one for each thermistor).

Daily Minimum Air Temperature: The lowest reading from the previous day. (three values, one for each thermistor).

Hourly Raw Table:

Hourly Sample Sensor Resistance: Recorded at the top of each hour. "Raw" data in k $\Omega$ . (three values, one for each thermistor)

Hourly Average Sensor Resistance: Average of the 60 one-minute readings for the previous hour. "Raw" data in k $\Omega$ . (three values, one for each thermistor).

**Water Height**

Sensor: Two CS450 (Campbell Scientific, inc) pressure transducer, SDI-12 type sensors

Pressure Measurement Range: 0-7.25 psig

Output Units: cm, ft (water height above sensor), psig

Scan Interval: 60 seconds

Output to Tables:

Fifteen-Minute Water Height Table:

Fifteen-Minute Sample Water Height: Fifteen minute sample (point) reading recorded at the top of the hour, 15, 30, and 45 minutes past the hour.

Fifteen-Minute Average Water Height: Fifteen minute average of all 15 readings recorded at the top of the hour, 15, 30, and 45 minutes past the hour.

Fifteen-Minute Maximum Water Height: Fifteen minute maximum of all 15 readings recorded at the top of the hour, 15, 30, and 45 minutes past the hour.

Fifteen-Minute Minimum Water Height: Fifteen minute minimum of all 15 readings recorded at the top of the hour, 15, 30, and 45 minutes past the hour.

Daily Table:

Daily Average Water Height: Average of all readings for the previous day.

Daily Maximum Water Height: Maximum water height for the previous day.

Daily Minimum Water Height: Minimum water height for the previous day.

**Water Temperature**

Sensor: Two CS450 (Campbell Scientific, inc) SDI-12 Sensors

Operating Range: -10°C to 80°C

Output Units: °C

Scan Interval: 60 seconds

Output to Tables:

Fifteen-Minute Water Level Table:

Fifteen-Minute Sample Water Temperature: Fifteen minute sample (point) reading recorded at the top of the hour, 15, 30, and 45 minutes past the hour.

Fifteen-Minute Average Water Temperature: Fifteen minute average of all 15 readings recorded at the top of the hour, 15, 30, and 45 minutes past the hour.

Fifteen-Minute Maximum Water Temperature: The highest reading taken during the previous fifteen minutes.

Fifteen-Minute Minimum Water Temperature: The lowest reading taken during the previous fifteen minutes.

Daily Table:

Daily Average Water Temperature: Average of all readings for the previous day.

Daily Maximum Water Temperature: the highest reading taken during the previous day.

Daily Minimum Water Temperature: the lowest reading taken during the previous day.

**Water Temperature, Independent (Not Installed at this Station)**

Sensor: Five Model 109 (Campbell Scientific, inc) Sensors

Operating Range: -50°C to 70°C

Output Units: °C

Scan Interval: 60 seconds

Output to Tables:

Fifteen-Minute Water Level Table:

Fifteen-Minute Sample Water Temperature: Fifteen minute sample (point) reading recorded at the top of the hour, 15, 30, and 45 minutes past the hour.

Fifteen-Minute Average Water Temperature: Fifteen minute average of all 15 readings recorded at the top of the hour, 15, 30, and 45 minutes past the hour.

Fifteen-Minute Maximum Water Temperature: The highest reading taken during the previous fifteen minutes.

Fifteen-Minute Minimum Water Temperature: The lowest reading taken during the previous fifteen minutes.

Daily Table:

Daily Average Water Temperature: Average of all readings for the previous day.

Daily Maximum Water Temperature: the highest reading taken during the previous day.

Daily Minimum Water Temperature: the lowest reading taken during the previous day.

**Soil Temperature Profile**

Sensor: Twelve YSI Series 44033 thermistors

Operating Range: -80°C to +75°C

Installation: In back-filled bored hole.

Depths: 0, 5, 10, 15, 20, 30, 40, 60, 80, 100, 120, 150 cm, 1-12 thermistors (based on actual depth of bored drill hole)

Output Units: k $\Omega$ , °C.

Scan Interval: 60 seconds

Output to Tables:

- Hourly Subsurface Table:
  - Hourly Sample Soil Temperature: Recorded at the top of each hour. (twelve values, one for each thermistor).
  - Hourly Average Soil Temperature: Average of the 60 one-minute readings for the previous hour. (twelve values, one for each thermistor).
- Daily Table:
  - Daily Average Soil Temperature: Average of all temperature readings for the previous day ending at midnight AST. (twelve values, one for each thermistor).
- Hourly Raw Table:
  - Hourly Sample Sensor Resistance: Recorded at the top of each hour. "Raw" data in k $\Omega$ . (twelve values, one for each thermistor)
  - Hourly Average Sensor Resistance: Average of the 60 one-minute readings for the previous hour. "Raw" data in k $\Omega$ . (twelve values, one for each thermistor).

### **Battery Voltage**

Sensor: CH200

Output Units: V.

Scan Interval: 60 seconds

Output to Tables:

- Hourly Diagnostics Table:
  - Hourly Sample CR1000 Battery Voltage: Measured at the top of the hour.
  - Hourly Average CR1000 Battery Voltage: Average of the 60 one-minute readings for the previous hour.
  - Hourly Maximum CR1000 Battery Voltage: The highest reading from the previous hour.
  - Hourly Minimum CR1000 Battery Voltage: The lowest reading from the previous hour.

### **Battery Current**

Sensor: CH200

Output Units: A.

Scan Interval: 60 seconds

Output to Tables:

- Hourly Diagnostics Table:
  - Hourly Sample CR1000 Battery Current: Measured at the top of the hour.
  - Hourly Average CR1000 Battery Current: Average of the 60 one-minute readings for the previous hour.
  - Hourly Maximum CR1000 Battery Current: The highest reading from the previous hour.
  - Hourly Minimum CR1000 Battery Current: The lowest reading from the previous hour.

**Load Current**

Sensor: CH200

Output Units: A.

Scan Interval: 60 seconds

Output to Tables:

Hourly Diagnostics Table:

Hourly Sample Load Current: Measured at the top of the hour.

Hourly Average Load Current: Average of the 60 one-minute readings for the previous hour.

Hourly Maximum Load Current: The highest reading from the previous hour.

Hourly Minimum CR1000 Battery Current: The lowest reading from the previous hour.

**Solar Panel Voltage**

Sensor: CH200

Output Units: V.

Scan Interval: 60 seconds

Output to Tables:

Hourly Diagnostics Table:

Hourly Sample Solar Panel Voltage: Hourly reading at the top of the hour.

Hourly Average Solar Panel Voltage: Average of the 60 one-minute readings for the previous hour.

Hourly Maximum Solar Panel Voltage: The highest reading from the previous hour.

Hourly Minimum Solar Panel Voltage: The lowest reading from the previous hour.

**Solar Panel Current**

Sensor: CH200

Output Units: A.

Scan Interval: 60 seconds

Output to Tables:

Hourly Diagnostics Table:

Hourly Sample Solar Panel Current: Hourly reading at the top of the hour.

Hourly Average Solar Panel Current: Average of the 60 one-minute readings for the previous hour.

Hourly Maximum Solar Panel Current: The highest reading from the previous hour.

Hourly Minimum Solar Panel Current: The lowest reading from the previous hour.

**Datalogger (CR1000) Panel Temperature**

Sensor: CR1000 Internal thermistor

Output Units: °C.

Scan Interval: 60 seconds

Output to Tables:

Hourly Diagnostics Table:

Hourly Average CR1000 Panel Temperature: Average of the 60 one-minute readings for the previous hour.

**Voltage Regulator (CH200) Temperature**

Sensor: CH200

Output Units: °C.

Scan Interval: 60 seconds

Output to Tables:

Hourly Diagnostics Table:

Hourly Average CR1000 Panel Temperature: Average of the 60 one-minute readings for the previous hour.

**Resulting Final Storage Data Tables:**

See Datalogger Output Files Excel Document

**Notes**

Definitions:

Scan interval = sampling duration = scan rate

Time of maximum or minimum values is not recorded

Sample reading = instantaneous reading

Beginning of the hour = top of the hour

**Table B-2. This table is a condensed version of the Data Measurement and Recording surface-water metadata standards shown above for FA-128 (Slough 8A) site ESSFA128-1. This table is particularly useful in the programming of the dataloggers**

Susitna ESSFAW2 Focus Area Station Data Standards				Data Files				Table							
Surface Water				A	Station Diagnostics			HourlyDiag							
Last Update:	6/25/2013			B	Hourly met table			Hourly							
Last Update By:	R Paetzold			S	Hourly subsurface table			HrlySubs							
				P	15-min water table			QuarterHourlyWater							
				L	Hourly Raw Data (collected for field diagnostics)			HourlyRaw							
				M	Overall daily output			Daily							
<b>Key Analysis and Demonstration Questions</b>															
Determine the potential for generating hydroelectric power.															
<b>CSI Data Station Collection Standards Summary Table</b>															
Parameters	# Sensors	Units	Hourly Data				Fifteen-Minute Data				Daily Data				
			Sample Point	Avg	Max	Min	Sample Point	Avg	Max	Min	Sample Point	Avg	Max	Min	
- Air Temperature (YSI 44033)	3	°C	B	B								M	M	M	
- Air Temperature (YSI 44033)	3	ohms	L	L											
- Water Ht (CS450)	2	cm, ft, psig					P	P	P	P		M	M	M	
- Surface Water Temperature (CS450)	2	°C					P	P	P	P		M	M	M	
- Surface Water Temperature (CSI 109)*	5	°C					P	P	P	P		M	M	M	
- Soil Profile Temperature (YSI 44033)	12	°C	S	S								M			
- Soil Profile Temperature (YSI 44033)	12	ohms	L	L											
<b>Monitoring System Diagnostic Conditions</b>															
- Station ID	na	number	A,B,L,S					P				M			
- Battery Voltage	1	V	A	A	A	A									
- Battery Current	1	A	A	A	A	A									
- Load Current	1	A	A	A	A	A									
- Solar Panel Voltage	1	V	A	A	A	A									
- Solar Panel Current	1	A	A	A	A	A									
- CR1000 Temperature	1	°C		A											
- CH200 Voltage Regulator Temperature	1	°C		A											

\* Sensor Not Installed



The following describes self-logger data measurement and recording standards for FA-115 (Slough 6A) station ESGFA115-8, representative of a groundwater station with an INW PT2X type station:

## SUSITNA HYDROLOGY PROJECT

### ESGFA115-8 MONITORING WELL STATION

#### DATA MEASUREMENT AND RECORDING STANDARDS

Last Update: 07/04/2013

Last Update By: R Paetzold

#### Monitoring Well Station

Data-Collection Objectives: Meteorological data to evaluate the potential for hydro-electric power generation in the Susitna River region.

Time Recording Standard: **Always** Alaska Standard Time (UTC – 9).

Datalogger Scan Interval Standard: 15 minutes.

#### Time Measurement Standards:

- Hourly readings are recorded at the end of the hour; therefore, the hourly average water temperature, for example, with a 60-second scan interval and a time stamp of 14:00 is measured from 13:01 to 14:00:00. For a 60-second scan interval, the hourly average would be the average of 60 min = 60 values.
- Quarter-hourly readings are recorded every fifteen minutes starting at the top of the hour.
- Instantaneous readings are taken at the time specified by the time stamp.
- A day begins at midnight (00:00:00) and ends at midnight (23:59:55). All daily data are from the day prior to the date of the time stamp. For example, if the time stamp reads 09/09/2007 00:00 or 09/09/2007 12:00:00 AM, the data are from 09/08/2007.

Data Retrieval Interval: Data will be retrieved manually.

Data Reporting Interval: Quarter-hourly.

#### WATER HEIGHT

Sensor: INW PT2X integrated datalogger and pressure/temperature sensor.

Pressure Measurement Range: 0-15 psig

Output Units: psig

Scan Interval: 15 minutes

Output:

Fifteen-Minute Sample Water Height: Fifteen minute sample (point) reading recorded at the top of the hour, 15, 30, and 45 minutes past the hour.

## **WATER TEMPERATURE**

Sensor: INW PT2X integrated datalogger and pressure/temperature sensor.

Sensor Range: -40°C to 125°C

Output Units: °C

Scan Interval: 15 minutes

Output:

Fifteen-Minute Sample Water Temperature: Fifteen minute average of all 15 readings recorded at the top of the hour, 15, 30, and 45 minutes past the hour.

## **RESULTING FINAL STORAGE DATA TABLES:**

See Datalogger Output Files Excel Document

### **Notes**

Definitions:

Scan interval = sampling duration = scan rate

Time of maximum or minimum values is not recorded

Sample reading = instantaneous reading

Beginning of the hour = top of the hour

The following describes meteorological data measurement and recording standards for FA-104 (Whiskers Slough) station ESMFA104-2, representative of a meteorological CSI CR1000 type station:

## SUSITNA HYDROLOGY PROJECT

### ESMFA104-2 Focus Area Clearing Met Station

#### Data Measurement and Recording Standards

Last Update: 06/28/2013

Last Update By: AMcHugh

#### Focus Area Station

Data-Collection Objectives: Meteorological data to evaluate the potential for hydro-electric power generation in the Susitna River region.

Time Recording Standard: **Always** Alaska Standard Time (UTC – 9).

Datalogger Scan Interval Standard: 60 seconds.

Time Measurement Standards:

Hourly readings are recorded at the end of the hour; therefore, the hourly average water temperature, for example, with a 60-second scan interval and a time stamp of 14:00 is measured from 13:01 to 14:00:00. For a 60-second scan interval, the hourly average would be the average of 60 min = 60 values.

Quarter-hourly readings are recorded every fifteen minutes starting at the top of the hour.

Instantaneous readings are taken at the time specified by the time stamp.

A day begins at midnight (00:00:00) and ends at midnight (23:59:55). All daily data are from the day prior to the date of the time stamp. For example, if the time stamp reads 09/09/2007 00:00 or 09/09/2007 12:00:00 AM, the data are from 09/08/2007.

Data Retrieval Interval: Data will be retrieved hourly.

Data Reporting Interval: Hourly

#### Images

Camera: Moultrie Game camera; not connected to data logger.

Memory Card: 16GB SD Flash Memory Card

Flash Card Capacity: ~20,000 Images or over 1 year

Images Taken: On camera's internal time interval.

Images Saved on Camera Memory Card: Half-hourly Lo-Resolution

Images Saved on Datalogger: Not connected to data logger.

Image Trigger Interval: 30-minutes

Data Retrieval: Manually, during station visits.

#### Air Temperature

Sensor: HC2S3 AT/RH sensor (PT100 RTD, IEC 751 1/3 Class B, with calibrated signal conditioning).

Measurement Range: -40°C to +60°C.

Accuracy: ±0.1°C @23°C (~±0.3°C at -40°C).

Installation: In 10-plate radiation shield, non-aspirated.

Height: 2 meters.

Output Units: °C.

Scan Interval: 60 seconds.

Output to Tables:

- Hourly Table:
  - Hourly Sample Air Temperature: Recorded at the top of each hour.
  - Hourly Average Air Temperature: 60 readings from the beginning of the hour to the end of the hour, averaged and recorded at the end of the hour.
  - Hourly Maximum Air Temperature: The highest reading from the previous hour.
  - Hourly Minimum Air Temperature: The lowest reading from the previous hour.
- Hourly Climate Table:
  - Hourly Minimum Air Temperature: Recorded at the top of each hour.
- Fifteen-Minute Met Table:
  - Fifteen-Minute Sample Air Temperature: Fifteen-minute sample (point) reading recorded at the top of the hour, 15, 30, and 45 minutes past the hour.
  - Fifteen-Minute Average Air Temperature: Fifteen-minute average of all 15 readings recorded at the top of the hour, 15, 30, and 45 minutes past the hour.
  - Fifteen-Minute Maximum Air Temperature: The highest reading from the previous fifteen minutes.
  - Fifteen-Minute Minimum Air Temperature: The lowest reading from the previous fifteen minutes.
- Daily Table:
  - Daily Average Air Temperature: Average of all temperature readings for the previous day ending at midnight AST.
  - Daily Maximum Air Temperature: The highest reading taken during the previous day.
  - Daily Minimum Air Temperature: The lowest reading taken during the previous day.

### **Relative Humidity**

Sensor: HC2S3 AT/RH sensor (ROTRONIC Hygromer® IN1).

Operating Range: 0 to 100% RH.

Accuracy: ±0.8% @23°C (~±0.3% at -40°C).

Installation: In 12-gill radiation shield, non-aspirated.

Height: 2 meters

Output Units: % Relative Humidity

Scan Interval: 60 seconds

Output to Tables:

Hourly Atmospheric Table:

Hourly Sample Relative Humidity: Recorded at the top of each hour.

Hourly Average Relative Humidity: 60 readings from the beginning of the hour to the end of the hour, averaged and recorded at the end of the hour.

Hourly Maximum Relative Humidity: The highest reading from the previous hour.

Hourly Minimum Relative Humidity: The lowest reading from the previous hour.

Fifteen-Minute Met Table:

Fifteen-Minute Sample Relative Humidity: Fifteen-minute sample (point) reading recorded at the top of the hour, 15, 30, and 45 minutes past the hour.

Fifteen-Minute Average Relative Humidity: Fifteen-minute average of all 15 readings recorded at the top of the hour, 15, 30, and 45 minutes past the hour.

- Fifteen-Minute Maximum Relative Humidity: The highest reading from the previous fifteen minutes.
- Fifteen-Minute Minimum Relative Humidity: The lowest reading from the previous fifteen minutes.
- Hourly Climate Table:
  - Hourly Sample Relative Humidity: Recorded at the top of each hour.
- Daily Table:
  - Daily Maximum Relative Humidity: the highest reading taken during the previous day.
  - Daily Minimum Relative Humidity: the lowest reading taken during the previous day.

### **Dew Point Temperature**

Sensor: Calculated value from AT/RH

Scan Interval: N/A, calculated

Output to Tables:

Hourly Table:

Hourly Sample Dew Point: Calculated from the Sample Air Temperature and Relative Humidity values at the top of each hour.

Hourly Average Dew Point: Average of the 60 values calculated from the 60-second Air Temperature and Relative Humidity values.

Hourly Maximum Dew Point: The highest reading from the previous hour.

Hourly Minimum Dew Point: The lowest reading from the previous hour.

Fifteen-Minute Met Table:

Fifteen-Minute Sample Dew Point: Fifteen-minute sample (point) calculation recorded at the top of the hour, 15, 30, and 45 minutes past the hour.

Fifteen-Minute Average Dew Point: Fifteen-minute average of all 15 calculations recorded at the top of the hour, 15, 30, and 45 minutes past the hour.

Fifteen-Minute Maximum Dew Point: The highest reading from the previous fifteen minutes.

Fifteen-Minute Minimum Dew Point: The lowest reading from the previous fifteen minutes.

Hourly Climate Table:

Hourly Sample Dew Point: Recorded at the top of each hour.

Daily Table:

Daily Maximum Dew Point: The highest calculated value during the previous day.

Daily Minimum Dew Point: The lowest calculated value during the previous day.

### **Vapor Pressure**

Sensor: Vapor Pressure Actual, Saturated and Deficit calculated value from AT/RH

Scan Interval: N/A, calculated

Output to Tables:

Hourly Table:

Hourly Sample Dew Point: Calculated from the Sample Air Temperature and Relative Humidity values at the top of each hour.

Hourly Average Dew Point: Average of the 60 values calculated from the 60-second Air Temperature and Relative Humidity values.

- Hourly Maximum Dew Point: The highest reading from the previous hour.
- Hourly Minimum Dew Point: The lowest reading from the previous hour.
- Fifteen-Minute Met Table:
  - Fifteen-Minute Sample Dew Point: Fifteen-minute sample (point) calculation recorded at the top of the hour, 15, 30, and 45 minutes past the hour.
  - Fifteen-Minute Average Dew Point: Fifteen-minute average of all 15 calculations recorded at the top of the hour, 15, 30, and 45 minutes past the hour.
  - Fifteen-Minute Maximum Dew Point: The highest reading from the previous fifteen minutes.
  - Fifteen-Minute Minimum Dew Point: The lowest reading from the previous fifteen minutes.
- Hourly Climate Table:
  - Hourly Sample Dew Point: Recorded at the top of each hour.
- Daily Table:
  - Daily Maximum Dew Point: The highest calculated value during the previous day.
  - Daily Minimum Dew Point: The lowest calculated value during the previous day.

## Wind Speed

Sensor: RM Young 05103-45 Wind Monitor (Alpine).

Operating Range: 0 to 100 m/s (0 to 224 mph).

Accuracy:  $\pm 0.3$  m/s ( $\pm 0.6$  mph) or 1% of reading.

Starting Threshold: 1 m/s (2.2 mph).

Installation: 30 m from nearest obstruction.

Height: 3 m.

Output Units: meters per second.

Scan Interval: 3s.

Output to Tables:

Hourly Met Table:

Instantaneous Wind Speed: The 3-second wind speed sampled at the top of the hour.

Hourly Average Wind Speed: Hourly average of 1200 three-second wind speed readings for the previous hour.

Hourly Peak Wind Speed: the highest recorded 3-second wind observation from the reporting interval of the past hour (max wind).

Fifteen-Minute Met Table:

Instantaneous Wind Speed: The 3-second wind speed sampled at the top of the hour, 15, 30, and 45 minutes past the hour.

Fifteen-Minute Average Wind Speed: Fifteen-minute average of all three hundred 3-second readings recorded at the top of the hour, 15, 30, and 45 minutes past the hour.

Fifteen-Minute Peak Wind Speed: the highest recorded 3-second wind observation from the reporting interval of the past fifteen minutes (max wind).

Two-Minute Wind Table:

Two-Minute Average Wind Speed: 2-minute average of 3-second wind speeds.

Two-Minute Peak Wind Speed: the highest recorded 3-second wind observation from the reporting interval of the past 2 minutes (max wind).

Hourly Climate Table:

Hourly Sample Wind Speed: Recorded at the top of each hour.

• Daily Table:

- Daily Average Wind Speed: The daily average of all 5-second wind speeds for the previous day.
- Daily Peak Wind Speed: The highest recorded 5-sec wind speed for the previous day.

**Wind Direction**

Sensor: RM Young 05103-45 Wind Monitor (Alpine).

Operating Range: 0 to 360 deg (mechanical) True North (0 to 355 electrical, 5 deg open).

Accuracy:  $\pm 5^\circ$ .

Starting Threshold: 1.1 m/s (2.4 mph) 10 deg displacement.

Installation: Align true north.

Height: 3 meters.

Output Units: degrees true north.

Scan Interval: 3s.

Output to Tables:

Hourly Atmospheric Table:

Instantaneous Wind Direction: Wind direction sample at the top of the hour.

Hourly Average Wind Direction: Hourly average of 3-second wind direction vector for the previous hour.

Fifteen-Minute Met Table:

Instantaneous Wind Direction: The 3-second wind direction vector sampled at the top of the hour, 15, 30, and 45 minutes past the hour.

Fifteen-Minute Average Wind Direction: Fifteen-minute average of all three hundred 3-second readings recorded at the top of the hour, 15, 30, and 45 minutes past the hour.

Two-Minute Wind Table:

Two-Minute Average Wind Direction: 2-minute average of 3-second wind direction vector.

Hourly Climate Table:

Hourly Sample Wind Direction: Recorded at the top of each hour.

Daily Table:

Daily Wind Direction: Vector mean of all wind direction readings for the previous day.

**Wind Direction Standard Deviation**

Sensor: Calculated.

Scan Interval: 3s.

Output to Tables:

Hourly Atmospheric Table:

Hourly Wind Direction Standard Deviation: The standard deviation (computed by the datalogger) of the wind direction over the one hour recording period.

Fifteen-Minute Met Table:

Fifteen-Minute Wind Direction Standard Deviation: The standard deviation (computed by the datalogger) of the wind direction over the fifteen-minute recording period.

Two-Minute Wind Table:

- Two-Minute Wind Direction Standard Deviation: The standard deviation (computed by the datalogger) of the wind direction over the 2-minute recording period)
- Daily Table:
  - Daily Wind Direction Standard Deviation: The standard deviation (computed by the datalogger) of the wind direction for the previous 24 hours.

**Wind Chill Temperature**

Sensor: Calculated from Air Temperature & Wind Speed. Wind Sensor

Output Units: °C.

Scan Interval: N/A, calculated.

Algorithms:  $WC = 35.74 + 0.6215 T - 35.75(V^{0.16}) + 0.4275T(V^{0.16})$

where:

WC = Wind Chill (°F)

T = Air Temperature (°F)

V = Wind Speed (mph)

Source: Alaska Safety Handbook. 2006. p180.

$WC (°C) = (WC - 32) * 5/9$

where:

WC (°C) = Wind Chill (°C)

Output to Tables:

- Hourly Atmospheric Table:
  - Instantaneous Wind Chill: Calculated from the Instantaneous Air Temperature and Wind Speed values sampled at the top of the hour.
  - Hourly Average Wind Chill: Average of the 60 values calculated from the 60-second sample Air Temperature and the average of the 60 corresponding 3-second sample wind speed values.
  - Hourly Maximum Wind Chill: The highest reading from the previous hour.
  - Hourly Minimum Wind Chill: The lowest reading from the previous hour.
- Fifteen-Minute Met Table:
  - Instantaneous Wind Chill: Calculated from the Instantaneous Air Temperature and Wind Speed values sampled at the top of the hour, 15, 30, and 45 minutes past the hour.
  - Fifteen-Minute Average Wind Chill: Average of the 15 values calculated from the 60-second sample Air Temperature and the average of the 15 corresponding 3-second sample wind speed values.
  - Fifteen-Minute Maximum Wind Chill: The highest reading from the previous fifteen minutes.
  - Fifteen-Minute Minimum Wind Chill: The lowest reading from the previous fifteen minutes.
- Hourly Climate Table:
  - Hourly Sample Wind Chill: Recorded at the top of each hour.
- Daily Table:
  - Daily Maximum Wind Chill: The highest calculated value during the previous day.
  - Daily Minimum Wind Chill: The lowest calculated value during the previous day.



**Solar Radiation**

Sensor: Campbell Scientific LI200X, LiCor LI200 pyranometer.

Height: 2 meters.

Output Units: mV, converted by datalogger to  $W/m^2$ .

Scan Interval: 60 seconds.

Output to Tables:

Hourly Met Table:

Hourly Average Solar Radiation: 60 readings from the beginning of the hour to the end of the hour, averaged and recorded at the end of the hour.

Hourly Average Solar Radiation: 60 readings from the beginning of the hour to the end of the hour, averaged and recorded at the end of the hour.

Fifteen-Minute Met Table:

Fifteen-Minute Average Solar Radiation: Fifteen-minute average of all 15 readings recorded at the top of the hour, 15, 30, and 45 minutes past the hour.

Hourly Climate Table:

Hourly Sample Solar Radiation: Recorded at the top of each hour.

Daily Table:

Daily Average Solar Radiation: The daily average of all solar radiation measurements for the previous day.

**Barometric Pressure**

Sensor: Campbell Scientific CS100, Setra 278

Height: 2 meters.

Range: 600 to 1100mBar

Output Units: mBar, Not Corrected to sea level

Scan Interval: 60 seconds.

Output to Tables:

Hourly Atmospheric Table:

Hourly Sample Barometric Pressure: Recorded at the top of each hour.

Fifteen-Minute Met Table:

Fifteen-Minute Sample Barometric Pressure: Fifteen-minute sample (point) reading recorded at the top of the hour, 15, 30, and 45 minutes past the hour.

Hourly Climate Table:

Hourly Sample Barometric Pressure: Recorded at the top of each hour.

**Net Radiation**

Sensor: Kipp and Zonen NR Lite2 Net Radiometer

Height: 2 meters.

Output Units: mV converted by datalogger to  $W/m^2$ , Wind Corrected  $W/m^2$

Scan Interval: 60 seconds.

Output to Tables:

Hourly Met Table:

Hourly Sample Net Radiation, Net Radiation w/ Wind Correction: Recorded at the top of each hour.

- Hourly Average Net Radiation, Net Radiation w/ Wind Correction: 60 readings from the beginning of the hour to the end of the hour, averaged and recorded at the end of the hour.
- Fifteen-Minute Met Table:
  - Fifteen-Minute Sample Net Radiation, Net Radiation w/ Wind Correction: Recorded at the top of each hour.
  - Fifteen-Minute Average Net Radiation, Net Radiation w/ Wind Correction: Fifteen-minute average of all 15 readings recorded at the top of the hour, 15, 30, and 45 minutes past the hour.
- Hourly Climate Table:
  - Hourly Sample Net Radiation, Net Radiation w/ Wind Correction: Recorded at the top of each hour.
- Hourly Raw Table:
  - Hourly Sample Sensor mV: Recorded at the top of each hour. "Raw" data in mV.
  - Hourly Average Sensor mV: Average of the 60 one-minute readings for the previous hour. "Raw" data in mV.

### **Air Temperature - Back Up**

Sensor: Triplicate YSI Series 44033 thermistors

Operating Range: -80°C to +75°C

Installation: In 6-gill radiation shield, non-aspirated.

Height: 2 meters

Output Units: kΩ, °C.

Scan Interval: 60 seconds

Output to Tables:

Hourly Atmospheric Table:

Hourly Sample Air Temperature: Recorded at the top of each hour. (three values, one for each thermistor).

Hourly Average Air Temperature: Average of the 60 one-minute readings for the previous hour. (three values, one for each thermistor).

Hourly Maximum Air Temperature: The highest reading from the previous hour.

Hourly Minimum Air Temperature: The lowest reading from the previous hour.

Hourly Climate Table:

Hourly Sample Air Temperature: Recorded at the top of each hour. (three values, one for each thermistor).

Fifteen-Minute Met Table:

Fifteen-Minute Sample Air Temperature: Fifteen-minute sample (point) reading recorded at the top of the hour, 15, 30, and 45 minutes past the hour.

Fifteen-Minute Average Air Temperature: Fifteen-minute average of all 15 readings recorded at the top of the hour, 15, 30, and 45 minutes past the hour.

Fifteen-Minute Maximum Air Temperature: The highest reading from the previous fifteen minutes.

Fifteen-Minute Minimum Air Temperature: The lowest reading from the previous fifteen minutes.

Hourly Raw Table:

- Hourly Sample Sensor Resistance: Recorded at the top of each hour. "Raw" data in k $\Omega$ . (three values, one for each thermistor)
- Hourly Average Sensor Resistance: Average of the 60 one-minute readings for the previous hour. "Raw" data in k $\Omega$ . (three values, one for each thermistor).
- Daily Table:
  - Daily Average Air Temperature: Average of all temperature readings for the previous day ending at midnight AST. (three values, one for each thermistor).
  - Daily Maximum Air Temperature: The highest reading from the previous day. (three values, one for each thermistor).
  - Daily Minimum Air Temperature: The lowest reading from the previous day. (three values, one for each thermistor).

**Water Height**

Sensor: One CS451 (Campbell Scientific, inc) pressure transducer, SDI-12 type sensor or one INW PT12 (Instruments North West) pressure transducer, SDI-12 type sensor.

Pressure Measurement Range: 0-7.25 psig

Output Units: cm, ft (water height above sensor), psig

Scan Interval: 60 seconds

Output to Tables:

Fifteen-Minute Water Table:

Fifteen-Minute Sample Water Height: Fifteen minute sample (point) reading recorded at the top of the hour, 15, 30, and 45 minutes past the hour.

Fifteen-Minute Average Water Height: Fifteen minute average of all 15 readings recorded at the top of the hour, 15, 30, and 45 minutes past the hour.

Fifteen-Minute Maximum Water Height: Fifteen minute maximum of all 15 readings recorded at the top of the hour, 15, 30, and 45 minutes past the hour.

Fifteen-Minute Minimum Water Height: Fifteen minute minimum of all 15 readings recorded at the top of the hour, 15, 30, and 45 minutes past the hour.

Hourly Climate Table:

Hourly Sample Water Height: Sample at the top of each hour.

Daily Table:

Daily Average Water Height: Average of all readings for the previous day.

Daily Maximum Water Height: Maximum water height for the previous day.

Daily Minimum Water Height: Minimum water height for the previous day.

**Water Temperature**

Sensor: One CS451 (Campbell Scientific, inc) SDI-12 sensor or one INW PT12 (Instruments North West) SDI-12 type sensor.

Operating Range: -10°C to 80°C

Output Units: °C

Scan Interval: 60 seconds

Output to Tables:

Fifteen-Minute Water Table:

Fifteen-Minute Sample Water Temperature: Fifteen minute sample (point) reading recorded at the top of the hour, 15, 30, and 45 minutes past the hour.

- Fifteen-Minute Average Water Temperature: Fifteen minute average of all 15 readings recorded at the top of the hour, 15, 30, and 45 minutes past the hour.
- Fifteen-Minute Maximum Water Temperature: The highest reading taken during the previous fifteen minutes.
- Fifteen-Minute Minimum Water Temperature: The lowest reading taken during the previous fifteen minutes.
- Hourly Climate Table:
  - Hourly Sample Water Temperature: Sample at the top of each hour.
- Daily Table:
  - Daily Average Water Temperature: Average of all readings for the previous day.
  - Daily Maximum Water Temperature: the highest reading taken during the previous day.
  - Daily Minimum Water Temperature: the lowest reading taken during the previous day.

### **Soil Temperature Profile**

Sensor: Twelve YSI Series 44033 thermistors

Operating Range: -80°C to +75°C

Installation: In back-filled bored hole.

Depths: 0, 5, 10, 15, 20, 30, 40, 60, 80, 100, 120, 150 cm, 1-12 thermistors (based on actual depth of bored drill hole)

Output Units: k $\Omega$ , °C.

Scan Interval: 60 seconds

Output to Tables:

Hourly Subsurface Table:

Hourly Sample Soil Temperature: Recorded at the top of each hour. (twelve values, one for each thermistor).

Hourly Average Soil Temperature: Average of the 60 one-minute readings for the previous hour. (twelve values, one for each thermistor).

Hourly Raw Table:

Hourly Sample Sensor Resistance: Recorded at the top of each hour. "Raw" data in k $\Omega$ . (twelve values, one for each thermistor)

Hourly Average Sensor Resistance: Average of the 60 one-minute readings for the previous hour. "Raw" data in k $\Omega$ . (twelve values, one for each thermistor).

Hourly Climate Table:

Hourly Sample Soil Temperature: Recorded at the top of each hour. (twelve values, one for each thermistor).

Daily Table:

Daily Average Soil Temperature: Average of all temperature readings for the previous day ending at midnight AST. (twelve values, one for each thermistor).

### **Soil Moisture Profile**

Sensor: Four sensors: CSI 650 Unfrozen Soil-Moisture/Soil Temperature Probes

Installation: Horizontal orientation in back-filled hole

Depths: 10, 20, 30, 40 cm

Output Units:  $\mu$ s, volumetric soil water content (v/v). Electrical Conductivity

Scan Interval: Hourly

Output to Tables:

- Hourly subsurface Table:
  - Hourly Instantaneous Soil Moisture: Hourly volumetric soil water content taken at the top of the hour (four values). Unitless volume ratio (water volume/soil volume).
- Hourly Raw Table:
  - Hourly Instantaneous Soil Moisture: Hourly "raw" volumetric soil water content taken at the top of the hour (four values). Units are  $\mu\text{s}$ .
- Hourly Climate Table:
  - Hourly Sample Soil Moisture: Recorded at the top of each hour (four values). Unitless volume ratio (water volume/soil volume).
- Daily Table:
  - Daily Average Soil Moisture: Average of all readings for the previous day ending at midnight AST (four values).
- Hourly Raw Table:
  - Hourly Sample Sensor Period: Recorded at the top of each hour. "Raw" data in  $\mu\text{Sec}$

### **Soil Temperature Profile 2**

Sensor: Four sensors: CSI 650 Unfrozen Soil-Moisture/Soil Temperature Probes

Installation: Horizontal orientation in back-filled hole

Depths: 10, 20, 30, 40 cm

Output Units: °C.

Scan Interval: Hourly

Output to Tables:

Hourly subsurface Table:

Hourly Instantaneous Soil Temperature: Hourly volumetric soil water content taken at the top of the hour (four values). Unitless volume ratio (water volume/soil volume).

Hourly Climate Table:

Hourly Sample Soil Temperature: Recorded at the top of each hour. (four values).

Daily Table:

Daily Average Soil Temperature: Average of all temperature readings for the previous day ending at midnight AST (four values).

### **Soil Moisture Electrical Conductivity**

Sensor: Four sensors: CSI 650 Unfrozen Soil-Moisture/Soil Temperature Probes

Installation: Horizontal orientation in back-filled hole

Depths: 10, 20, 30, 40 cm

Output Units: dS/m

Scan Interval: Hourly

Output to Tables:

Hourly Subsurface Table:

Hourly Instantaneous Soil Moisture Electrical Conductivity: Hourly soil water electrical conductivity taken at the top of the hour (four values).

Hourly Climate Table:

○ Hourly Sample Soil Moisture Electrical Conductivity: Recorded at the top of each hour (four values). Unitless volume ratio (water volume/soil volume).

- Daily Table:
  - Daily Average Soil Moisture Electrical Conductivity: Average of all readings for the previous day ending at midnight AST (four values).

**Soil Heat Flux**

Sensor: HFP01-L Hukseflux Soil heat Flux Plate

Operating Range: -2000 W/m<sup>2</sup> to +2000 W/m<sup>2</sup>

Installation: Horizontally in back-filled bored hole.

Depth: 8 cm

Output Units: W/m<sup>2</sup>, mV

Scan Interval: 60 seconds

Output to Tables:

Hourly Subsurface Table:

Hourly Average Soil Heat Flux: Average of the 60 one-minute readings for the previous hour.

Hourly Sample Soil Heat Flux: Recorded at the top of each hour.

Hourly Climate Table:

Hourly Sample Soil Heat Flux: Recorded at the top of each hour.

Daily Table:

Daily Average Soil Heat Flux: Average of all readings for the previous day ending at midnight AST.

Hourly Raw Table:

Hourly Sample Sensor mV: Recorded at the top of each hour. "Raw" data in mV.

Hourly Average Sensor mV: Average of the 60 one-minute readings for the previous hour. "Raw" data in mV.

**Battery Voltage**

Sensor: CH200

Output Units: V.

Scan Interval: 60 seconds

Output to Tables:

Hourly Diagnostics Table:

Hourly Sample CR1000 Battery Voltage: Measured at the top of the hour.

Hourly Average CR1000 Battery Voltage: Average of the 60 one-minute readings for the previous hour.

Hourly Maximum CR1000 Battery Voltage: The highest reading from the previous hour.

Hourly Minimum CR1000 Battery Voltage: The lowest reading from the previous hour.

**Battery Current**

Sensor: CH200

Output Units: A.

Scan Interval: 60 seconds

Output to Tables:

Hourly Diagnostics Table:

- Hourly Sample CR1000 Battery Current: Measured at the top of the hour.

- Hourly Average CR1000 Battery Current: Average of the 60 one-minute readings for the previous hour.
- Hourly Maximum CR1000 Battery Current: The highest reading from the previous hour.
- Hourly Minimum CR1000 Battery Current: The lowest reading from the previous hour.

**Load Current**

Sensor: CH200

Output Units: A.

Scan Interval: 60 seconds

Output to Tables:

Hourly Diagnostics Table:

Hourly Sample Load Current: Measured at the top of the hour.

Hourly Average Load Current: Average of the 60 one-minute readings for the previous hour.

Hourly Maximum Load Current: The highest reading from the previous hour.

Hourly Minimum CR1000 Battery Current: The lowest reading from the previous hour.

**Solar Panel Voltage**

Sensor: CH200

Output Units: V.

Scan Interval: 60 seconds

Output to Tables:

Hourly Diagnostics Table:

Hourly Sample Solar Panel Voltage: Hourly reading at the top of the hour.

Hourly Average Solar Panel Voltage: Average of the 60 one-minute readings for the previous hour.

Hourly Maximum Solar Panel Voltage: The highest reading from the previous hour.

Hourly Minimum Solar Panel Voltage: The lowest reading from the previous hour.

**Solar Panel Current**

Sensor: CH200

Output Units: A.

Scan Interval: 60 seconds

Output to Tables:

Hourly Diagnostics Table:

Hourly Sample Solar Panel Current: Hourly reading at the top of the hour.

Hourly Average Solar Panel Current: Average of the 60 one-minute readings for the previous hour.

Hourly Maximum Solar Panel Current: The highest reading from the previous hour.

Hourly Minimum Solar Panel Current: The lowest reading from the previous hour.

**Datalogger (CR1000) Panel Temperature**

Sensor: CR1000 Internal thermistor

Output Units: °C.

Scan Interval: 60 seconds

Output to Tables:

- Hourly Diagnostics Table:
  - Hourly Average CR1000 Panel Temperature: Average of the 60 one-minute readings for the previous hour.

### **Voltage Regulator (CH200) Temperature**

Sensor: CH200

Output Units: °C.

Scan Interval: 60 seconds

Output to Tables:

Hourly Diagnostics Table:

Hourly Average CR1000 Panel Temperature: Average of the 60 one-minute readings for the previous hour.

### **Resulting Final Storage Data Tables:**

See Datalogger Output Files Excel Document

### **Notes**

Definitions:

Scan interval = sampling duration = scan rate

Time of maximum or minimum values is not recorded

Sample reading = instantaneous reading

Beginning of the hour = top of the hour



**Table B-3. This table is a condensed version of the Data Measurement and Recording metadata standards shown above for FA-104 (Whiskers Slough) site ESMFA104-2.**

Sunitna ESMFA104-2 Clearing Met Station Data Standards			Data Files				Table											
Surface Water			A	Station Diagnostics			HourlyDiag											
Last Update: 6/28/2013			B	Hourly table for all measurements			Hourly											
Last Update By: AMcHugh			C	15-min met data			QuarterHrlyMet											
			K	2-minute table for wind			TwoMinWd											
			P	15-min water table			QuarterHourlyWater											
			L	Hourly Raw Data (collected for field diagnostics)			HourlyRaw											
			M	Overall daily output			Daily											
			D	Data for the Current Conditions Page			HrlyClimate											
			O	Hourly subsurface measurements			HourlySubs											
<b>Key Analysis and Demonstration Questions</b>																		
Determine the potential for generating hydroelectric power.																		
<b>CSI Data Station Collection Standards Summary Table</b>																		
Parameters	# Sensors	Units	Data Tables															
			Hourly Data				Fifteen-Minute Data				Two-Minute Data				Daily Data			
			Sample Point	Avg	Max	Min	Sample Point	Avg	Max	Min	Sample Point	Avg	Max	Min	Sample Point	Avg	Max	Min
- Air Temperature (3 YSI 44033 thermistors)	1	°C	B,D	B	B	B	C	C	C	C						M	M	M
- Air Temperature (Triplicate YSI 44033 thermistors)	1	ghms	L	L	L	L												
- Water Ht (CS451 or INW PT12)	1	cm, ft, psig	D				P	P	P	P						M	M	M
- Water Temperature (CS451 or INW PT12)	1	°C	D				P	P	P	P						M	M	M
- Air Temperature (HC2S3)	1	°C	B,D	B	B	B	C	C	C	C					M	M	M	
- Relative Humidity (HC2S3)	1	%	B,D	B	B	B	C	C	C	C								
- Dew Point (Calculated)		°C	B,D	B	B	B	C	C	C	C						M	M	M
- Vapor Pressure Actual (Calculated)		kPa	B,D	B	B	B	C	C	C	C							M	M
- Vapor Pressure Saturated (Calculated)		kPa	B,D	B	B	B	C	C	C	C							M	M
- Vapor Pressure Deficit (Calculated)		kPa	B,D	B	B	B	C	C	C	C							M	M
- Wind Speed (RM Young 05103-45)	1	m/s	B,D	B	B		C	C	C			K	K			M	M	
- Wind Direction (RM Young 05103-45)	1	°	B,D	B			C	C				K				M		
- Wind Direction Standard Deviation (RM Young 05103-45)		Unitless		B				C				K				M		
- Wind Chill Temperature (Calculated)		°C	B,D	B	B	B	C	C	C	C							M	M
- Solar Radiation (LI200X Pyranometer)	1	W/m <sup>2</sup>	B,D	B			C	C								M		
- Net Radiation (NR-LITE Kipp & Zonen Net Radiometer)	1	mV, W/m <sup>2</sup>	B,D,L	B,L			C	C								M		
- Net Radiation Wind Corrected (Calculated)	1	mV, W/m <sup>2</sup>	B,D,L	B,L			C	C								M		
- Precipitation (TE525MM Tipping Bucket Rain Gage)	1	mm	B <sup>1</sup> , D <sup>1</sup>					C <sup>1</sup>								M <sup>1</sup>		
- Soil Water Content (CS650 TDR Soil Water/T sensor)	4	vv	D,O													M		
- Soil Temperature (CS650 TDR Soil Water/T sensor)	4	°C	D,O													M		
- Soil Moisture EC (CS650 TDR Soil Water/T sensor)	4	dS/m	D,O													M		
- Soil Moisture period (CS650 TDR Soil Water/T sensor)	4	uS	L															
- Soil Temperature Profile (12 GWS YSI Thermistor String)	1	°C	D,O	O												M		
- Soil Temperature Profile (12 GWS YSI Thermistor String)	1	Kohms	L	L														
- Soil Heat Flux (Hukseflux)	1	W/m <sup>2</sup>	D,O	O												M		
- Soil Heat Flux (Hukseflux) raw	1	mV	L	L														
- Barometric Pressure CS100	1	mBar	B, D				C											
<b>Monitoring System Diagnostic Conditions</b>																		
- Station ID	na	number	A,B,D,L				C,P					K				M		
- Battery Voltage	1	V	A	A	A	A												
- Battery Current	1	A	A	A	A	A												
- Load Current	1	A	A	A	A	A												
- Solar Panel Voltage	1	V	A	A	A	A												
- Solar Panel Current	1	A	A	A	A	A												
- CR1000 Temperature	1	°C	A															
- CH200 Voltage Regulator Temperature	1	°C	A															
*Total																		
Manually collected images from Moultrie Game Camera																		

The following describes groundwater (CR200X logger) data measurement and recording standards for FA-104 (Whiskers Slough) station ESMFA104-3, representative of a groundwater CSI CR200X type station:

### Susitna Hydrology Project

#### ESSFA04-3 Groundwater Station

#### Data Measurement and Recording Standards

Last Update: 06/13/2013

Last Update By: AMcHugh

### Monitoring Well Station

Data-Collection Objectives: Meteorological data to evaluate the potential for hydro-electric power generation in the Susitna River region.

Time Recording Standard: Always Alaska Standard Time (UTC – 9).

Datalogger Scan Interval Standard: 60 seconds.

#### Time Measurement Standards:

Hourly readings are recorded at the end of the hour; therefore, the hourly average water temperature, for example, with a 60-second scan interval and a time stamp of 14:00 is measured from 13:01 to 14:00:00. For a 60-second scan interval, the hourly average would be the average of 60 min = 60 values.

Quarter-hourly readings are recorded every fifteen minutes starting at the top of the hour.

Instantaneous readings are taken at the time specified by the time stamp.

A day begins at midnight (00:00:00) and ends at midnight (23:59:55). All daily data are from the day prior to the date of the time stamp. For example, if the time stamp reads 09/09/2007 00:00 or 09/09/2007 12:00:00 AM, the data are from 09/08/2007.

Data Retrieval Interval: Data will be retrieved hourly.

Data Reporting Interval: Hourly

### Water Height

Sensor: Three CS451 (Campbell Scientific, inc) pressure transducer, SDI-12 type sensors

Pressure Measurement Range: 0-7.25 psig

Output Units: ft (water height above sensor), psig

Scan Interval: 60 seconds

Output to Tables:

#### Fifteen-Minute Water Height Table:

Fifteen-Minute Sample Water Height: Fifteen minute sample (point) reading recorded at the top of the hour, 15, 30, and 45 minutes past the hour.

Fifteen-Minute Average Water Height: Fifteen minute average of all 15 readings recorded at the top of the hour, 15, 30, and 45 minutes past the hour.

#### Hourly Climate Table:

Hourly Sample Water Height: Sample reading at the top of the hour.

**Daily Table:**

Daily Maximum Water Height: Maximum water height (in Feet only) for the previous day.

- Daily Minimum Water Height: Minimum water height (in Feet only) for the previous day.

**Surface-Water Temperature**

Sensor: Three CS451 (Campbell Scientific, inc) SDI-12 Sensors

Operating Range: -10°C to 80°C

Output Units: °C

Scan Interval: 60 seconds

Output to Tables:

**Fifteen-Minute Water Level Table:**

Fifteen-Minute Average Water Temperature: Fifteen minute average of all 15 readings recorded at the top of the hour, 15, 30, and 45 minutes past the hour.

**Hourly Climate Table:**

Hourly Sample Water Temperature: Sample reading at the top of the hour.

**Daily Table:**

Daily Maximum Water Temperature: the highest reading taken during the previous day.

Daily Minimum Water Temperature: the lowest reading taken during the previous day.

**Battery Voltage**

Sensor: CH200

Output Units: V.

Scan Interval: 60 seconds

Output to Tables:

**Hourly Diagnostics Table:**

Hourly Sample CR1000 Battery Voltage: Measured at the top of the hour.

Hourly Average CR1000 Battery Voltage: Average of the 60 one-minute readings for the previous hour.

**Battery Current**

Sensor: CH200

Output Units: A.

Scan Interval: 60 seconds

Output to Tables:

**Hourly Diagnostics Table:**

Hourly Sample CR1000 Battery Current: Measured at the top of the hour.

Hourly Average CR1000 Battery Current: Average of the 60 one-minute readings for the previous hour.

**Load Current**

Sensor: CH200

Output Units: A.

Scan Interval: 60 seconds

Output to Tables:

- Hourly Diagnostics Table:
  - Hourly Sample Load Current: Measured at the top of the hour.
  - Hourly Average Load Current: Average of the 60 one-minute readings for the previous hour.

**Solar Panel Voltage**

Sensor: CH200

Output Units: V.

Scan Interval: 60 seconds

Output to Tables:

Hourly Diagnostics Table:

Hourly Sample Solar Panel Voltage: Hourly reading at the top of the hour.

Hourly Average Solar Panel Voltage: Average of the 60 one-minute readings for the previous hour.

**Solar Panel Current**

Sensor: CH200

Output Units: A.

Scan Interval: 60 seconds

Output to Tables:

Hourly Diagnostics Table:

Hourly Sample Solar Panel Current: Hourly reading at the top of the hour.

Hourly Average Solar Panel Current: Average of the 60 one-minute readings for the previous hour.

**Voltage Regulator (CH200) Temperature**

Sensor: CH200

Output Units: °C.

Scan Interval: 60 seconds

Output to Tables:

Hourly Diagnostics Table:

Hourly Average CR1000 Panel Temperature: Average of the 60 one-minute readings for the previous hour.

**Resulting Final Storage Data Tables:**

See Datalogger Output Files Excel Document

**Notes**

Definitions:

Scan interval = sampling duration = scan rate

Time of maximum or minimum values is not recorded

Sample reading = instantaneous reading

Beginning of the hour = top of the hour

**Table B-4. This table is a condensed version of the Data Measurement and Recording groundwater (CR200X logger) metadata standards shown above for FA-104 (Whiskers Slough) site ESMFA104-3.**

Susitna ESSFA104-3 Groundwater Station Data Standards				Data Files	File Description	Table									
Ground Water				A	Station Diagnostics	HourlyDiag									
Last Update:	6/28/2013			D	Data for the Current Conditions Page	HrlyClimate									
Last Update By:	AMcHugh			P	15-min water table	QuarterHrWater									
				M	Overall daily output	Daily									
<b>Key Analysis and Demonstration Questions</b>															
Determine the potential for generating hydroelectric power.															
<b>CSI Data Station Collection Standards Summary Table</b>															
Parameters	# Sensors	Units	Data Tables												
			Hourly Data			Fifteen-Minute Data			Daily Data						
			Sample Point	Avg	Max	Min	Sample Point	Avg	Max	Min	Sample Point	Avg	Max	Min	
- Water Ht. (CS451)	3	ft, psig	D				P	P						M	M
- Surface Water Temperature (CS451)	3	°C	D				P							M	M
<b>Monitoring System Diagnostic Conditions</b>															
- Station ID	na	number	A,D				P							M	
- Battery Voltage	1	V	A	A											
- Battery Current	1	A	A	A											
- Load Current	1	A	A	A											
- Solar Panel Voltage	1	V	A	A											
- Solar Panel Current	1	A	A	A											
- CH200 Voltage RegulatorTemperature	1	°C	A	A											

\* Sensor Not Installed

The following describes groundwater with sap flow data measurement and recording standards for FA-104 (Whiskers Slough) station ESMFA104-4, representative of a groundwater CSI CR1000 with sap flow sensors type station:

### Susitna Hydrology Project

#### ESGFA104-6 Focus Area Well Head with Sap Flow Station

#### Data Measurement and Recording Standards

Last Update: 07/23/2013

Last Update By: R Paetzold

### Focus Area Station

Data-Collection Objectives: Meteorological data to evaluate the potential for hydro-electric power generation in the Susitna River region.

Time Recording Standard: Always Alaska Standard Time (UTC – 9).

Datalogger Scan Interval Standard: 60 seconds.

Time Measurement Standards:

Hourly readings are recorded at the end of the hour; therefore, the hourly average water temperature, for example, with a 60-second scan interval and a time stamp of 14:00 is measured from 13:01 to 14:00:00. For a 60-second scan interval, the hourly average would be the average of 60 min = 60 values.

Quarter-hourly readings are recorded every fifteen minutes starting at the top of the hour.

Instantaneous readings are taken at the time specified by the time stamp.

A day begins at midnight (00:00:00) and ends at midnight (23:59:55). All daily data are from the day prior to the date of the time stamp. For example, if the time stamp reads 09/09/2007 00:00 or 09/09/2007 12:00:00 AM, the data are from 09/08/2007.

Data Retrieval Interval: Data will be retrieved hourly.

Data Reporting Interval: Hourly

### Sap Flow Measurements 1

Sensor: 22 TDP30 Thermal Dissipation Probe Sensors

Installation: Sensors comprised of two thermocouples and heater are inserted in tree. Three or four sensors per tree.

Height: TBD meters

Output Units: Depends on the measurement.

Scan Interval: 60 seconds

Output to Tables:

TableDT (Hourly):

Hourly Average Differential Thermocouple Temperature (°C): Average of the 60 one-minute readings for the previous hour. (one value for each sensor).

TableHR (Hourly):

Hourly Accumulated Sap Flow (g/hr): Accumulated sap flow, sum of the 60 one-minute readings for the previous hour. (one value).

TableTC (Hourly):

- Hourly Sample Average Differential Thermocouple Temperature (°C): Hourly sample (point) reading recorded at the top of the hour. (one value for each sensor)
- Hourly Sample Maximum Differential Thermocouple Temperature (°C): Hourly sample (point) reading recorded at the top of the hour. (one value for each sensor)
  - Hourly Sample Thermocouple Sap Velocity (cm/hr): Hourly sample (point) reading recorded at the top of the hour. (one value for each sensor)
  - Hourly Sample Thermocouple Sap Flow (g/hr): Hourly sample (point) reading recorded at the top of the hour. (one value for each sensor)
  - Hourly Sample Thermocouple Status: Hourly sample (point) reading recorded at the top of the hour. (one value for each sensor)
  - Hourly Sample Thermocouple Heater Voltage (V): Hourly sample (point) reading recorded at the top of the hour. (one value for each sensor)
- TableTDP (Hourly):
    - Hourly Sample TDP Sap Flow (g/hr): Hourly sample (point) reading recorded at the top of the hour. (one value for each sensor)
    - Hourly Sample TDP Sap Flow Index: Hourly sample (point) reading recorded at the top of the hour. (one value for each sensor)
    - Hourly Sample TDP Status: Hourly sample (point) reading recorded at the top of the hour. (one value for each sensor)
  - Daily Raw Table:
    - Hourly Sample Sensor String: Recorded at the top of each day (midnight AST). TDP Type, Index Area, dTM1, SA1, dTM2, SA2, dTM3, SA3 for each sensor.
  - TableDY (Daily):
    - Sample Daily Total Sap Flow: Accumulated total daily sap flow for the previous day ending at midnight AST. (one value for all sensors).
    - Sample Daily Maximum Sap Flow: The highest reading from the previous day. (one value for each sensor).

## Sap Flow Measurements 2

Sensor: 10 TDP50 Thermal Dissipation Probe Sensors

Installation: Sensors comprised of two thermocouples and heater are inserted in tree. Three or four sensors per tree.

Height: TBD meters

Output Units: Depends on the measurement.

Scan Interval: 60 seconds

Output to Tables:

TableDT (Hourly):

Hourly Average Differential Thermocouple Temperature (°C): Average of the 60 one-minute readings for the previous hour. (one value for each sensor).

TableHR (Hourly):

Hourly Accumulated Sap Flow (g/hr): Accumulated sap flow, sum of the 60 one-minute readings for the previous hour. (one value).

TableTC (Hourly):

Hourly Sample Average Differential Thermocouple Temperature (°C): Hourly sample (point) reading recorded at the top of the hour. (one value for each sensor)

- Hourly Sample Maximum Differential Thermocouple Temperature (°C): Hourly sample (point) reading recorded at the top of the hour. (one value for each sensor)
- Hourly Sample Thermocouple Sap Velocity (cm/hr): Hourly sample (point) reading recorded at the top of the hour. (one value for each sensor)
  - Hourly Sample Thermocouple Sap Flow (g/hr): Hourly sample (point) reading recorded at the top of the hour. (one value for each sensor)
  - Hourly Sample Thermocouple Status: Hourly sample (point) reading recorded at the top of the hour. (one value for each sensor)
  - Hourly Sample Thermocouple Heater Voltage (V): Hourly sample (point) reading recorded at the top of the hour. (one value for each sensor)
- TableTDP (Hourly):
    - Hourly Sample TDP Sap Flow (g/hr): Hourly sample (point) reading recorded at the top of the hour. (one value for each sensor)
    - Hourly Sample TDP Sap Flow Index: Hourly sample (point) reading recorded at the top of the hour. (one value for each sensor)
    - Hourly Sample TDP Status: Hourly sample (point) reading recorded at the top of the hour. (one value for each sensor)
  - Daily Raw Table:
    - Hourly Sample Sensor String: Recorded at the top of each day (midnight AST). TDP Type, Index Area, dTM1, SA1, dTM2, SA2, dTM3, SA3 for each sensor.
  - TableDY (Daily):
    - Sample Daily Total Sap Flow: Accumulated total daily sap flow for the previous day ending at midnight AST. (one value for all sensors).
    - Sample Daily Maximum Sap Flow: The highest reading from the previous day. (one value for each sensor).

## **Water Height**

Sensor: One CS451 (Campbell Scientific, inc) pressure transducer, SDI-12 type sensors

Pressure Measurement Range: 0-7.25 psig

Output Units: cm, ft (water height above sensor), psig

Scan Interval: 60 seconds

Output to Tables:

Fifteen-Minute Water Height Table:

Fifteen-Minute Sample Water Height: Fifteen minute sample (point) reading recorded at the top of the hour, 15, 30, and 45 minutes past the hour.

Fifteen-Minute Average Water Height: Fifteen minute average of all 15 readings recorded at the top of the hour, 15, 30, and 45 minutes past the hour.

Fifteen-Minute Maximum Water Height: Fifteen minute maximum of all 15 readings recorded at the top of the hour, 15, 30, and 45 minutes past the hour.

Fifteen-Minute Minimum Water Height: Fifteen minute minimum of all 15 readings recorded at the top of the hour, 15, 30, and 45 minutes past the hour.

Hourly Climate Table:

Hourly Sample Water Height: Sample at the top of each hour. This table is for the Current Conditions page on the Diag Site only.

Daily Table:

Daily Average Water Height: Average of all readings for the previous day.



- Daily Maximum Water Height: Maximum water height for the previous day.
- Daily Minimum Water Height: Minimum water height for the previous day.

### **Water Temperature**

Sensor: One CS451 (Campbell Scientific, inc) SDI-12 Sensors

Operating Range: -10°C to 80°C

Output Units: °C

Scan Interval: 60 seconds

Output to Tables:

Fifteen-Minute Water Level Table:

Fifteen-Minute Sample Water Temperature: Fifteen minute sample (point) reading recorded at the top of the hour, 15, 30, and 45 minutes past the hour.

Fifteen-Minute Average Water Temperature: Fifteen minute average of all 15 readings recorded at the top of the hour, 15, 30, and 45 minutes past the hour.

Fifteen-Minute Maximum Water Temperature: The highest reading taken during the previous fifteen minutes.

Fifteen-Minute Minimum Water Temperature: The lowest reading taken during the previous fifteen minutes.

Hourly Climate Table:

Hourly Sample Water Temperature: Sample at the top of each hour. This table is for the Current Conditions page on the Diag Site only.

Daily Table:

Daily Average Water Temperature: Average of all readings for the previous day.

Daily Maximum Water Temperature: the highest reading taken during the previous day.

Daily Minimum Water Temperature: the lowest reading taken during the previous day.

### **Battery Voltage**

Sensor: CH200

Output Units: V.

Scan Interval: 60 seconds

Output to Tables:

Hourly Diagnostics Table:

Hourly Sample CR1000 Battery Voltage: Measured at the top of the hour.

Hourly Average CR1000 Battery Voltage: Average of the 60 one-minute readings for the previous hour.

Hourly Maximum CR1000 Battery Voltage: The highest reading from the previous hour.

Hourly Minimum CR1000 Battery Voltage: The lowest reading from the previous hour.

### **Battery Current**

Sensor: CH200

Output Units: A.

Scan Interval: 60 seconds

Output to Tables:

Hourly Diagnostics Table:

- Hourly Sample CR1000 Battery Current: Measured at the top of the hour.

- Hourly Average CR1000 Battery Current: Average of the 60 one-minute readings for the previous hour.
- Hourly Maximum CR1000 Battery Current: The highest reading from the previous hour.
- Hourly Minimum CR1000 Battery Current: The lowest reading from the previous hour.

**Load Current**

Sensor: CH200

Output Units: A.

Scan Interval: 60 seconds

Output to Tables:

Hourly Diagnostics Table:

Hourly Sample Load Current: Measured at the top of the hour.

Hourly Average Load Current: Average of the 60 one-minute readings for the previous hour.

Hourly Maximum Load Current: The highest reading from the previous hour.

Hourly Minimum CR1000 Battery Current: The lowest reading from the previous hour.

**Solar Panel Voltage**

Sensor: CH200

Output Units: V.

Scan Interval: 60 seconds

Output to Tables:

Hourly Diagnostics Table:

Hourly Sample Solar Panel Voltage: Hourly reading at the top of the hour.

Hourly Average Solar Panel Voltage: Average of the 60 one-minute readings for the previous hour.

Hourly Maximum Solar Panel Voltage: The highest reading from the previous hour.

Hourly Minimum Solar Panel Voltage: The lowest reading from the previous hour.

**Solar Panel Current**

Sensor: CH200

Output Units: A.

Scan Interval: 60 seconds

Output to Tables:

Hourly Diagnostics Table:

Hourly Sample Solar Panel Current: Hourly reading at the top of the hour.

Hourly Average Solar Panel Current: Average of the 60 one-minute readings for the previous hour.

Hourly Maximum Solar Panel Current: The highest reading from the previous hour.

Hourly Minimum Solar Panel Current: The lowest reading from the previous hour.

**Datalogger (CR1000) Panel Temperature**

Sensor: CR1000 Internal thermistor

Output Units: °C.

Scan Interval: 60 seconds

Output to Tables:

- Hourly Diagnostics Table:
  - Hourly Average CR1000 Panel Temperature: Average of the 60 one-minute readings for the previous hour.

### **Voltage Regulator (CH200) Temperature**

Sensor: CH200

Output Units: °C.

Scan Interval: 60 seconds

Output to Tables:

Hourly Diagnostics Table:

Hourly Average CR1000 Panel Temperature: Average of the 60 one-minute readings for the previous hour.

### **Battery Capacity**

Sensor: CH200

Output Units: Ahr.

Scan Interval: 60 seconds

Output to Tables:

Hourly Diagnostics Table:

Hourly Sample Previous Battery Capacity (NEWBATTCAP): Hourly reading at the top of the hour.

Hourly Sample Present Battery Capacity (BattCap): Hourly reading at the top of the hour.

### **Daily Cumulative Battery Current**

Sensor: CH200

Output Units: Ahr.

Scan Interval: 60 seconds

Output to Tables:

Hourly Diagnostics Table:

Hourly Sample Cumulative Battery Current In: Hourly reading at the top of the hour; cumulative to midnight.

Hourly Sample Cumulative Battery Current Out: Hourly reading at the top of the hour; cumulative to midnight.

### **Battery Charge Power**

Sensor: CH200

Output Units: W.

Scan Interval: 60 seconds

Output to Tables:

- Hourly Diagnostics Table:
  - Hourly Average Power to Charge Battery: Average of the 60 one-minute readings for the previous hour.
  - Hourly Maximum Power to Charge Battery: Maximum of the 60 one-minute readings for the previous hour.

- Hourly Minimum Power to Charge Battery: Minimum of the 60 one-minute readings for the previous hour.

**Load Power**

Sensor: CH200

Output Units: W.

Scan Interval: 60 seconds

Output to Tables:

Hourly Diagnostics Table:

Hourly Average Power Used by Load: Average of the 60 one-minute readings for the previous hour.

Hourly Maximum Power Used by Load: Maximum of the 60 one-minute readings for the previous hour.

Hourly Minimum Power Used by Load: Minimum of the 60 one-minute readings for the previous hour.

**Charger State**

Sensor: CH200

Output: -1 = regulator fault, 0 = no charge, 1 = current limited charging, 2 = cycle charging, 3 = float charging, 4 = battery test.

Scan Interval: 60 seconds

Output to Tables:

Hourly Diagnostics Table:

Hourly Sample Charge State: Hourly reading at the top of the hour.

**Resulting Final Storage Data Tables:**

See Datalogger Output Files Excel Document

**Notes**

Definitions:

Scan interval = sampling duration = scan rate

Time of maximum or minimum values is not recorded

Sample reading = instantaneous reading

Beginning of the hour = top of the hour

**Table B-5. This table is a condensed version of the Data Measurement and Recording groundwater with sap flow metadata standards shown above for FA-104 (Whiskers Slough) site ESMFA104-4.**

ESGFA104-4 Well Head with Sap Flow Station Data Standards	Data Files	Table
Ground Water with Sap Flow	A Station Diagnostics	HourlyDiag
Last Update: 7/27/2013	D Data for the Current Conditions Page	HrlyClimate
Last Update By: R Paetzold	P 15-min water table	QuarterHourlyWater
	H Daily Raw Data	DailyRaw
	M Overall daily output	Daily
<b>Key Analysis and Demonstration Questions</b>	U Hourly sample differential sap flow thermocouple measurements	TableTC
Determine the potential for generating hydroelectric power.	V Hourly average differential sap flow thermocouple measurements	TableDT
	W Hourly sap flow	TableTDP
	Y Hourly accumulated sap flow	TableHR
	Z Daily sap flow	TableDY

CSI Data Station Collection Standards Summary Table			Data Tables											
Parameters	# Sensors	Units	Hourly Data			Fifteen-Minute Data				Daily Data				
			Sample Point	Avg	Max	Min	Sample Point	Avg	Max	Min	Sample Point	Avg	Max	Min
<b>Water Level</b>														
- Water Ht (CS451)	1	cm, ft, psig	D				P	P	P	P		M	M	M
- Surface Water Temperature (CS451)	1	°C	D				P	P	P	P		M	M	M
<b>Sap Flow - TDP30</b>														
- TDP Type	22											H		
- Index Area	22											H		
- dTM1; Max Temperature Difference between sensor thermocouple	22	°C										H		
- SA1; Cross-sectional Area	22	cm <sup>2</sup>										H		
- dTM2; Max Temperature Difference between sensor thermocouple	22	°C										H		
- SA2; Cross-sectional Area	22	cm <sup>2</sup>										H		
- dTM3; Max Temperature Difference between sensor thermocouple	22	°C										H		
- SA3; Cross-sectional Area	22	cm <sup>2</sup>										H		
- TC_dTC; Differential Thermocouple Temperature	22	°C		V										
- Day of Year	22			U,W,Y								Z		
- Time of Day; Hour, Minute	22			U,W,Y										
- TC_dTCa; Avg Differential Thermocouple Temperature	22	°C		U										
- TC_dTM; Max Differential Thermocouple Temperature	22	°C		U,Z										
- TC_Vel; Thermocouple Sap Velocity	22	cm/hr		U										
- TC_Flow; Thermocouple Sap Flow	22	g/hr		U,W										
- TC_Flowlx	22			W										
- TC_Status; Sensor Status	22			U,W										
- HtrV_Saqp Flow Sensor Heater Voltage	4	V		U										
- Hr_Flow; Hourly Accumulated Sap Flow	22	g/hr		Y										
- DY_Flow; Accumulated Daily Sap Flow	1											Z		
<b>Sap Flow - TDP50</b>														
- TDP Type	10											H		
- Index Area	10											H		
- dTM1; Max Temperature Difference between sensor thermocouple	10	°C										H		
- SA1; Cross-sectional Area	10	cm <sup>2</sup>										H		
- dTM2; Max Temperature Difference between sensor thermocouple	10	°C										H		
- SA2; Cross-sectional Area	10	cm <sup>2</sup>										H		
- dTM3; Max Temperature Difference between sensor thermocouple	10	°C										H		
- SA3; Cross-sectional Area	10	cm <sup>2</sup>										H		
- TC_dTC; Differential Thermocouple Temperature	10	°C		V										
- Day of Year	10			U,W,Y								Z		
- Time of Day; Hour, Minute	10			U,W,Y										
- TC_dTCa; Avg Differential Thermocouple Temperature	10	°C		U										
- TC_dTM; Max Differential Thermocouple Temperature	10	°C		U,Z										
- TC_Vel; Thermocouple Sap Velocity	10	cm/hr		U										
- TC_Flow; Thermocouple Sap Flow	10	g/hr		U,W										
- TC_Flowlx	10			W										
- TC_Status; Sensor Status	10			U,W										
- HtrV_Saqp Flow Sensor Heater Voltage	4	V		U										
- Hr_Flow; Hourly Accumulated Sap Flow	10	g/hr		Y										
- DY_Flow; Accumulated Daily Sap Flow	1											Z		
<b>Monitoring System Diagnostic Conditions</b>														
- Station ID	na	number	A,D,U,V,W,Y					P				H,M,Z		
- Battery Voltage	1	V	A	A	A	A	A,U							
- Battery Current	1	A	A	A	A	A	A							
- Load Current	1	A	A	A	A	A	A							
- Solar Panel Voltage	1	V	A	A	A	A	A							
- Solar Panel Current	1	A	A	A	A	A	A							
- CR1000 Temperature	1	°C	A	A	A	U								
- CH200 Voltage Regulator Temperature	1	°C	A	A	A									
- NEWBATTCAP_Previos Battery Capacity	1	Ahr	A											
- BattCap; Current Battery Capacity	1	Ahr	A											
- Daily Cumulative Battery Current In	1	Ahr	A											
- Daily Cumulative Battery Current Out	1	Ahr	A											
- Charger Power; Avg Power to Charge Battery	1	W	A	A	A	A	A							
- Load Power; Avg Power used by Load	1	W	A	A	A	A	A							
- Charger State	1		A											

The following describes groundwater data measurement and recording standards for FA-104 (Whiskers Slough) station ESMFA104-10, representative of a groundwater CSI CR1000 type station with two temperature profile measurement sensors:

**Susitna Hydrology Project**  
**ESG104-10 Groundwater Station**  
**Data Measurement and Recording Standards**  
Last Update: 01/12/2014  
Last Update By: R Paetzold

## Groundwater Station

Data-Collection Objectives: Meteorological data to evaluate the potential for hydro-electric power generation in the Susitna River region.

Time Recording Standard: **Always** Alaska Standard Time (UTC – 9).

Datalogger Scan Interval Standard: 3 seconds.

Time Measurement Standards:

Hourly readings are recorded at the end of the hour; therefore, the hourly average water temperature, for example, with a 60-second scan interval and a time stamp of 14:00 is measured from 13:01 to 14:00:00. For a 60-second scan interval, the hourly average would be the average of 60 min = 60 values.

Quarter-hourly readings are recorded every fifteen minutes starting at the top of the hour.

Instantaneous readings are taken at the time specified by the time stamp.

A day begins at midnight (00:00:00) and ends at midnight (23:59:55). All daily data are from the day prior to the date of the time stamp. For example, if the time stamp reads 09/09/2007 00:00 or 09/09/2007 12:00:00 AM, the data are from 09/08/2007.

Data Retrieval Interval: Data will be retrieved hourly.

Data Reporting Interval: Hourly

## Images

Camera: Moultrie Game camera; not connected to data logger.

Memory Card: 16GB SD Flash Memory Card

Flash Card Capacity: ~20,000 Images or over 1 year

Images Taken: On camera's internal time interval.

Images Saved on Camera Memory Card: Half-hourly Lo-Resolution

Images Saved on Datalogger: Not connected to data logger.

Image Trigger Interval: 30-minutes

Data Retrieval: Manually, during station visits.

## Water Height

Sensor: Two CS451 (Campbell Scientific, inc) pressure transducer, SDI-12 type sensors. Note INW PT-12s may be substituted for one or more of the CS451s.

Pressure Measurement Range: 0-7.25 psig

Output Units: cm, ft (water height above sensor), psig

Scan Interval: 60 seconds

Output to Tables:

- Fifteen-Minute Water Table:
  - Fifteen-Minute Sample Water Height: Fifteen minute sample (point) reading recorded at the top of the hour, 15, 30, and 45 minutes past the hour for each sensor.
  - Fifteen-Minute Average Water Height: Fifteen minute average of all 15 readings recorded at the top of the hour, 15, 30, and 45 minutes past the hour for each sensor.
  - Fifteen-Minute Maximum Water Height: Fifteen minute maximum of all 15 readings recorded at the top of the hour, 15, 30, and 45 minutes past the hour for each sensor.
  - Fifteen-Minute Minimum Water Height: Fifteen minute minimum of all 15 readings recorded at the top of the hour, 15, 30, and 45 minutes past the hour for each sensor.
- Hourly Climate Table:
  - Hourly Sample Water Height: Sample at the top of each hour for each sensor.
- Daily Table:
  - Daily Average Water Height: Average of all readings for the previous day for each sensor.
  - Daily Maximum Water Height: Maximum water height for the previous day for each sensor.
  - Daily Minimum Water Height: Minimum water height for the previous day for each sensor.

### **Water Temperature**

Sensor: Two CS451 (Campbell Scientific, inc) pressure transducer, SDI-12 type sensors. Note INW PT-12s may be substituted for one or more of the CS451s.

Operating Range: -10°C to 80°C

Output Units: °C

Scan Interval: 60 seconds

Output to Tables:

Fifteen-Minute Water Table:

Fifteen-Minute Average Water Temperature: Fifteen minute average of all 15 readings recorded at the top of the hour, 15, 30, and 45 minutes past the hour for each sensor.

Fifteen-Minute Maximum Water Temperature: The highest reading taken during the previous fifteen minutes for each sensor.

Fifteen-Minute Minimum Water Temperature: The lowest reading taken during the previous fifteen minutes for each sensor.

Hourly Climate Table:

Hourly Sample Water Temperature: Sample at the top of each hour for each sensor.

Daily Table:

Daily Average Water Temperature: Average of all readings for the previous day for each sensor.

Daily Maximum Water Temperature: the highest reading taken during the previous day for each sensor.

Daily Minimum Water Temperature: the lowest reading taken during the previous day for each sensor.

**Water Electrical Conductivity**

Sensor: Two CS547A Probes.

Operating Range: 0°C to +50°C; 0.005 to 7.0 mS cm<sup>-1</sup>.

Cell Constant: Individually calibrated. The cell constant ( $K_c$ ) is found on a label near the termination of the cable.

Output Units: kΩ, mS cm<sup>-1</sup>

Scan Interval: 60 minutes

Output to Tables:

- Fifteen-Minute Water Table:
  - Fifteen-Minute Sample Water Electrical Conductivity: Fifteen minute sample (point) reading recorded at the top of the hour, 15, 30, and 45 minutes past the hour for each sensor.
  - Fifteen-Minute Average Water Electrical Conductivity: Fifteen minute average of all 15 readings recorded at the top of the hour, 15, 30, and 45 minutes past the hour for each sensor.
  - Fifteen-Minute Maximum Water Electrical Conductivity: Fifteen minute maximum of all 15 readings recorded at the top of the hour, 15, 30, and 45 minutes past the hour for each sensor.
  - Fifteen-Minute Minimum Water Electrical Conductivity: Fifteen minute minimum of all 15 readings recorded at the top of the hour, 15, 30, and 45 minutes past the hour for each sensor.
- Hourly Climate Table:
  - Hourly Sample Water Electrical Electrical Conductivity: Measured at the top of the hour for each sensor.
- Hourly Raw Table:
  - Hourly Sample Water Electrical Conductivity: Top of the hour measurement of water electrical conductivity each sensor, uncorrected for temperature.
  - Hourly Average Water Electrical Conductivity: Hourly average water electrical conductivity for each sensor, uncorrected for temperature.
- Daily Table:
  - Daily Average Water Electrical Conductivity: Average of all readings for the previous day for each sensor.
  - Daily Maximum Water Electrical Conductivity: Maximum of all readings for the previous day for each sensor.
  - Daily Minimum Water Electrical Conductivity: Minimum of all readings for the previous day for each sensor.

**Water Temperature at Electrical Conductivity Sensors**

Sensor: Two CS547A Probes with Betatherm 100K6A1 thermistors.

Operating Range: 0°C to +50°C

Output Units: °C.

Scan Interval: 60 minutes

Output to Tables:

Fifteen-Minute Water Table:

Fifteen-Minute Average Water Temperature: Fifteen minute average of all 15 readings recorded at the top of the hour, 15, 30, and 45 minutes past the hour for each sensor.



- Fifteen-Minute Maximum Water Temperature: The highest reading taken during the previous fifteen minutes for each sensor.
- Fifteen-Minute Minimum Water Temperature: The lowest reading taken during the previous fifteen minutes for each sensor.
- Hourly Climate Table:
  - Hourly Sample Water Temperature: Measured at the top of the hour for each sensor.
- Daily Table:
  - Daily Average Water Temperature: Average of all readings for the previous day for each sensor.
  - Daily Maximum Water Temperature: Maximum of all readings for the previous day for each sensor.
  - Daily Minimum Water Temperature: Minimum of all readings for the previous day for each sensor.

### **Soil Temperature Profile**

Sensor: Two GWS YSI Soil Profile Temperature Probes each with Twelve YSI Series 44033 thermistors.

Installation: Vertically in a drilled hole.

Depths: 0, 5, 10, 15, 20, 30, 40, 60, 80, 100, 120, 150 cm, 1-12 thermistors (based on actual depth of bored drill hole)

Output Units: k $\Omega$ , °C.

Scan Interval: 60 seconds

Output to Tables:

Hourly Subsurface Table:

Hourly Sample Soil Temperature: Recorded at the top of each hour. (twelve values for each probe, one for each thermistor).

Hourly Average Soil Temperature: Average of the 60 one-minute readings for the previous hour. (twelve values for each probe, one for each thermistor).

Hourly Raw Table:

Hourly Sample Sensor Resistance: Recorded at the top of each hour. "Raw" data in k $\Omega$ . (twelve values for each probe, one for each thermistor)

Hourly Average Sensor Resistance: Average of the 60 one-minute readings for the previous hour. "Raw" data in k $\Omega$ . (twelve values for each probe, one for each thermistor).

Hourly Climate Table:

Hourly Sample Soil Temperature: Recorded at the top of each hour. (twelve values for each probe, one for each thermistor).

Daily Table:

Daily Average Soil Temperature: Average of all temperature readings for the previous day ending at midnight AST. (twelve values for each probe, one for each thermistor).

### **Battery Voltage**

Sensor: CH200

Output Units: V.

Scan Interval: 60 seconds

**Output to Tables:**

- **Hourly Diagnostics Table:**
  - Hourly Sample CR1000 Battery Voltage: Measured at the top of the hour.
  - Hourly Average CR1000 Battery Voltage: Average of the 60 one-minute readings for the previous hour.
  - Hourly Maximum CR1000 Battery Voltage: The highest reading from the previous hour.
  - Hourly Minimum CR1000 Battery Voltage: The lowest reading from the previous hour.

**Battery Current**

Sensor: CH200

Output Units: A.

Scan Interval: 60 seconds

Output to Tables:

Hourly Diagnostics Table:

Hourly Sample CR1000 Battery Current: Measured at the top of the hour.

Hourly Average CR1000 Battery Current: Average of the 60 one-minute readings for the previous hour.

Hourly Maximum CR1000 Battery Current: The highest reading from the previous hour.

Hourly Minimum CR1000 Battery Current: The lowest reading from the previous hour.

**Load Current**

Sensor: CH200

Output Units: A.

Scan Interval: 60 seconds

Output to Tables:

Hourly Diagnostics Table:

Hourly Sample Load Current: Measured at the top of the hour.

Hourly Average Load Current: Average of the 60 one-minute readings for the previous hour.

Hourly Maximum Load Current: The highest reading from the previous hour.

Hourly Minimum CR1000 Battery Current: The lowest reading from the previous hour.

**Solar Panel Voltage**

Sensor: CH200

Output Units: V.

Scan Interval: 60 seconds

Output to Tables:

- **Hourly Diagnostics Table:**
  - Hourly Sample Solar Panel Voltage: Hourly reading at the top of the hour.
  - Hourly Average Solar Panel Voltage: Average of the 60 one-minute readings for the previous hour.
  - Hourly Maximum Solar Panel Voltage: The highest reading from the previous hour.
  - Hourly Minimum Solar Panel Voltage: The lowest reading from the previous hour.

**Solar Panel Current**

Sensor: CH200

Output Units: A.

Scan Interval: 60 seconds

Output to Tables:

- Hourly Diagnostics Table:
  - Hourly Sample Solar Panel Current: Hourly reading at the top of the hour.
  - Hourly Average Solar Panel Current: Average of the 60 one-minute readings for the previous hour.
  - Hourly Maximum Solar Panel Current: The highest reading from the previous hour.
  - Hourly Minimum Solar Panel Current: The lowest reading from the previous hour.

**Datalogger (CR1000) Panel Temperature**

Sensor: CR1000 Internal thermistor

Output Units: °C.

Scan Interval: 60 seconds

Output to Tables:

Hourly Diagnostics Table:

Hourly Average CR1000 Panel Temperature: Average of the 60 one-minute readings for the previous hour.

**Voltage Regulator (CH200) Temperature**

Sensor: CH200

Output Units: °C.

Scan Interval: 60 seconds

Output to Tables:

Hourly Diagnostics Table:

Hourly Average CR1000 Panel Temperature: Average of the 60 one-minute readings for the previous hour.

**Resulting Final Storage Data Tables:**

See Datalogger Output Files Excel Document

**Notes**

Definitions:

Scan interval = sampling duration = scan rate

Time of maximum or minimum values is not recorded

Sample reading = instantaneous reading

Beginning of the hour = top of the hour

**Table B-6. This table is a condensed version of the Data Measurement and Recording groundwater metadata standards shown above for FA-104 (Whiskers Slough) site ESMFA104-10.**

Susitna ESGFA104-10 Groundwater Station Data Standards				Data Files	Table									
Surface Water				A	Station Diagnostics	HourlyDiag								
Last Update: 1/12/2014				B	Hourly table for all measurements	Hourly								
Last Update By: R Paetzold				C	15-min met data	QuarterHrlyMet								
<b>Key Analysis and Demonstration Questions</b>				K	2-minute table for wind	TwoMinWd								
Determine the potential for generating hydroelectric power.				P	15-min water table	QuarterHourlyWater								
				L	Hourly Raw Data (collected for field diagnostics)	HourlyRaw								
				M	Overall daily output	Daily								
				D	Data for the Current Conditions Page	HrlyClimate								
				O	Hourly subsurface measurements	HourlySubs								
<b>CSI Data Station Collection Standards Summary Table</b>														
Parameters	# Sensors	Units	Data Tables											
			Hourly Data				Fifteen-Minute Data				Daily Data			
			Sample Point	Avg	Max	Min	Sample Point	Avg	Max	Min	Sample Point	Avg	Max	Min
- Water Ht (CS451 or INW PT12)	2	cm, ft, psig	D				P	P	P	P	M	M	M	
- Water Temperature (CS451 or INW PT12)	2	°C	D				P	P	P	P	M	M	M	
- Water Electrical Conductivity (CS547A)	2	kΩ, mS cm <sup>-1</sup>	D,L		L		P	P	P	P	M	M	M	
- Water Temperature (CS547A)	2	°C	D				P	P	P	P	M	M	M	
Soil Temperature Profile (12 GWS YSI Thermistor String)	2	°C	D,L,O		L,O						M			
<b>Monitoring System Diagnostic Conditions</b>														
- Station ID	na	number	A,D,L,O				P				M			
- Battery Voltage	1	V	A	A	A	A								
- Battery Current	1	A	A	A	A	A								
- Load Current	1	A	A	A	A	A								
- Solar Panel Voltage	1	V	A	A	A	A								
- Solar Panel Current	1	A	A	A	A	A								
- CR1000 Temperature	1	°C		A										
- CH200 Voltage Regulator Temperature	1	°C		A										
Manually collected images from Motree Game Camera														

**Susitna-Watana Hydroelectric Project  
(FERC No. 14241)**

**Groundwater Study (7.5)**

**Appendix C**

**Groundwater Study Data-Collection Station Programs  
and Wiring Diagram Examples**

**Initial Study Report**

Prepared for

Alaska Energy Authority



**SUSITNA-WATANA HYDRO**

*Clean, reliable energy for the next 100 years.*

Prepared by

Geo-Watersheds Scientific

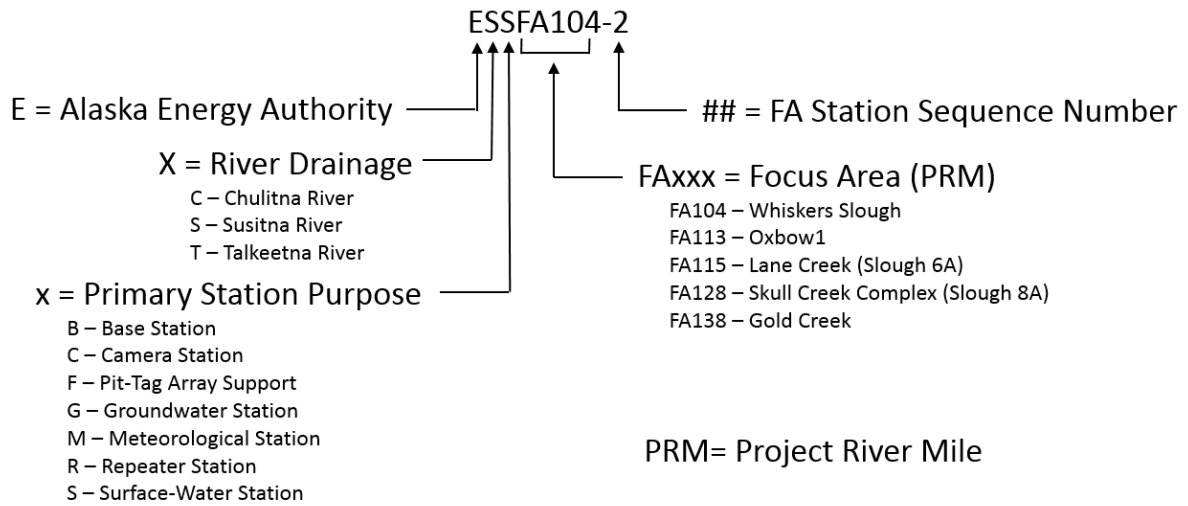
February 2014 Draft

## APPENDIX C: GROUNDWATER STUDY DATA-COLLECTION STATION PROGRAMS AND WIRING DIAGRAM EXAMPLES

The Groundwater Study data-collection station programs and wiring diagrams help ensure the collection of quality datasets. The examples within this appendix show the range of standard wiring diagrams and programs for various types of stations to meet study objectives. The primary station types include surface-water, groundwater, and meteorological stations. Station programs and wiring diagrams have been created for each station type.

**Table C-1. This table lists representative station types with corresponding programs and wiring diagrams for each station type. Following the table, example programming and wiring diagrams for surface-water, groundwater, and meteorological stations are provided.**

Focus Area	Primary Station Purpose (variation)	Representative Station
FA-128 (Slough 8A)	Surface-Water (CSI CR1000)	ESSFA128-1
FA-104 (Whiskers Slough)	Meteorological (CSI CR1000)	ESMFA104-2
FA-104 (Whiskers Slough)	Groundwater (CSI CR200X)	ESGFA104-3
FA-104 (Whiskers Slough)	Groundwater (CR1000, sap flow sensors)	ESGFA104-4
FA-104 (Whiskers Slough)	Groundwater (CSI CR1000, stream-bed profiles)	ESGFA104-10



**Figure C-1. Data collection station short name convention used for continuously monitored stations.** Most stations collect data for multiple study objectives. This allows for improved efficiency of synoptic data collection and data collection standards.



**The following program and wiring diagrams depict FA-128 (Slough 8A) station ESSFA128-1, representative of the surface-water (CSI CR1000) type station:**

'CR1000 Series Datalogger

'Modification Of: ESSFA104-1\_20130719.cr1

'Modified by: AMcHugh

'Date Modified: 07/19/2013

'Modifications: Changed StationName

'Modification Of: ESSFAW1\_20130401.cr1

'Modified by: AMcHugh

'Date Modified: 07/19/2013

'Modifications: Added CH200 code.

'Modification Of: ESSFA\_20130121.cri

'Modified by: R Paetzold

'Date Modified: 04/01/2013

'Modifications: New station with two cameras, two pressure transducers, GWS YSI Air T sensor, multiplexer, and soil profile temperature string.

'Program Name: ESSRA\_20130121.cr1

'Modification Of: ESS10\_20121212.cr1

'Modified by: AMcHugh

'Date Modified:

'Modifications:

'Station Notes:

' PakBus ID for Station: 520 'INSERT PakBus ID HERE <=====

' Station ID: 520 'INSERT Station ID HERE <=====

' Time is set to AK Standard Time

.....

"" INDIVIDUAL STATION INPUTS ""

.....

'INSERT Station Name HERE:

StationName (ESSFA128-1) 'INSERT Station Name HERE

<=====

'INSERT Station ID HERE:

Const ID = 520 'INSERT Station ID HERE <=====

'FIXED RESISTOR VALUES FOR GWS THERMISTOR CIRCUITS

'INSERT FIXED RESISTOR #1 (EX1 to SE1) MEASURED VALUE (kOHM) HERE:

\*\*\*\*\*

Const Rf\_1 = 1.000

'INSERT FIXED RESISTOR #2 (EX1 to SE2) MEASURED VALUE (kOHM) HERE:

\*\*\*\*\*

Const Rf\_2 = 1.000

'INSERT FIXED RESISTOR #3 (EX1 to SE3) MEASURED VALUE (kOHM) HERE:

\*\*\*\*\*

Const Rf\_3 = 1.000

'YSI thermistor conversion:

'kOHM to deg C

Const a = 0.0014654354

Const b = 0.0002386780

Const c = 0.0000001000

'CONTROL PORTS

' C1 CH200 - Charging Regulator

' C2 AM16/32B - Multiplexer, RES

' C3 AM16/32B - Multiplexer, CLK

' C4 CC5MPXWD Camera #1 Trigger

' C5 PT1 - CS450 Pressure Transducer

' C6 CC5MPXWD Camera #2 Trigger

' C7 PT2 - CS450 Pressure Transducer

' C8

' SW12V

'DECLARE PUBLIC VARIABLES

PreserveVariables ' variables are maintained over reboot.

Public MinIntoDay ' computed value from rTime

Public StationID ' Station ID number, USER INPUT

Public BattVolts\_V

Public LoggerTemp\_C

Public DlyBatCrtIn\_AHr, DlyBatCrtOut\_AHr

Public LoadPwr\_W, ChargePwr\_W

Public CH200\_M0(9) 'Array to hold all data from CH200

Public CH200\_MX(4) ' Array to hold extended data from CH200

Alias CH200\_MX(1) = BattTargV ' Battery charging target voltage

Alias CH200\_MX(2) = DgtlPotSet ' Digital potentiometer setting

Alias CH200\_MX(3) = BattCap ' Present battery capacity

Alias CH200\_MX(4) = Qloss ' Battery charge deficit

' SDI-12 formatted battery capacity value

Public SDI12command As String

' Response from CH200. Retrns the address of the unit and "ok" if all went well  
 Public SDI12result As String  
 Public NEWBATTCAP ' the new battery capacity if you need to change it.

Public CS450Data1(2) 'Water Level Sensor 1 - pressure, temperature  
 Public CS450Data2(2) 'Water Level Sensor 2 - pressure, temperature  
 Public WaterHt1\_cm, WaterHt1\_ft, WaterHt2\_cm, WaterHt2\_ft ' Water level above the  
 probe  
 Public Therm\_kOhm(15), TEMP\_C(15) 'YSI thermistors - air temperature (1-3), soil  
 temperature (4-15)  
 Public WaterT\_C(5) 'CSI 109 temperature sensor - water temperature

Public TAKEIMAGE

Public IMAGERATE\_MIN ' Adjust this for the image rate.  
 Public STARTIMAGEMID ' time as Minutes Into Day to START taking images  
 Public STOPIMAGEMID ' time as Minutes Into Day to STOP taking images.  
 Public CAMERAMANCONTROL As String \* 2 'on or off  
 Public CAMERADEFROSTERMODE As String \* 2 ' manual or auto  
 Public CAMERADEFROSTERMANCONTROL As String \* 2 ' on or off  
 Public CAMERADEFROSTERONMID ' time as Minutes Into Day to turn Camera Heat On  
 Public CAMERADEFROSTEROFFMID ' time as Minutes Into Day to turn Camera Heat Off  
 Public TurnDefrosterOn As Boolean  
 Public TurnDefrosterVal As Long  
 Public SendVarResult As Long

Public TAKEIMAGE2

Public IMAGE2RATE\_MIN ' adjust this for the image rate  
 Public STARTIMAGE2MID ' time as Minutes Into Day to START taking images  
 Public STOPIMAGE2MID ' time as Minutes Into Day to STOP taking images.  
 Public CAMERA2MANCONTROL As String \* 2 'on or off  
 Public CAMERA2DEFROSTERMODE As String \* 2 ' manual or auto  
 Public CAMERA2DEFROSTERMANCONTROL As String \* 2 ' on or off  
 Public CAMERA2DEFROSTERONMID ' time as Minutes Into Day to turn Camera Heat On  
 Public CAMERA2DEFROSTEROFFMID ' time as Minutes Into Day to turn Camera Heat Off  
 Public TurnDefroster2On As Boolean  
 Public TurnDefroster2Val As Long  
 Public SendVarResult2 As Long

Dim Initialized  
 Dim therm(15)  
 Dim i  
 Dim D(15)  
 Dim FixedRes(3)

Alias CS450Data1(1) = WaterHt1\_psi

Alias CS450Data1(2) = WaterT1\_C  
 Alias CS450Data2(1) = WaterHt2\_psi  
 Alias CS450Data2(2) = WaterT2\_C

Alias TEMP\_C(1) = AirT\_YSI1\_C  
 Alias TEMP\_C(2) = AirT\_YSI2\_C  
 Alias TEMP\_C(3) = AirT\_YSI3\_C

Alias Temp\_C(4) = SoilT\_5cm\_C  
 Alias Temp\_C(5) = SoilT\_10cm\_C  
 Alias Temp\_C(6) = SoilT\_15cm\_C  
 Alias Temp\_C(7) = SoilT\_20cm\_C  
 Alias Temp\_C(8) = SoilT\_30cm\_C  
 Alias Temp\_C(9) = SoilT\_40cm\_C  
 Alias Temp\_C(10) = SoilT\_50cm\_C  
 Alias Temp\_C(11) = SoilT\_60cm\_C  
 Alias Temp\_C(12) = SoilT\_80cm\_C  
 Alias Temp\_C(13) = SoilT\_100cm\_C  
 Alias Temp\_C(14) = SoilT\_120cm\_C  
 Alias Temp\_C(15) = SoilT\_150cm\_C

Alias CH200\_M0(1)=CH200BattVolts\_V 'Battery voltage: VDC  
 Alias CH200\_M0(2)=BattCrnt\_A 'Current going into, or out of, the battery: Amps  
 Alias CH200\_M0(3)=LoadCrnt\_A 'Current going to the load: Amps  
 Alias CH200\_M0(4)=SolarPanel\_V 'Voltage coming into the charger: VDC  
 Alias CH200\_M0(5)=SolarPanel\_A 'Current coming into the charger: Amps  
 Alias CH200\_M0(6)=Chgr\_Tmp\_C 'Charger temperature: Celsius  
 Alias CH200\_M0(7)=Chgr\_State 'Charging state: 2=Cycle, 3=Float, 1=Current Limited, or  
 0=None  
 Alias CH200\_M0(8)=Chgr\_Source 'Charging source: 0=None, 1=Solar, or 2=AC  
 Alias CH200\_M0(9)=Ck\_Batt 'Check battery error: 0=normal, 1=check battery

' Real time variable assigned

Public rTime(9) 'declare as public and dimension rTime to 9  
 Alias rTime(1) = Year 'assign the alias Year to rTime(1)  
 Alias rTime(2) = Month 'assign the alias Month to rTime(2)  
 Alias rTime(3) = DOM 'assign the alias Day to rTime(3)  
 Alias rTime(4) = Hour 'assign the alias Hour to rTime(4)  
 Alias rTime(5) = Minute 'assign the alias Minute to rTime(5)  
 Alias rTime(6) = Second 'assign the alias Second to rTime(6)  
 Alias rTime(7) = uSecond 'assign the alias uSecond to rTime(7)  
 Alias rTime(8) = WeekDay 'assign the alias WeekDay to rTime(8)  
 Alias rTime(9) = Day\_of\_Year 'assign the alias Day\_of\_Year to rTime(9)

## ' 15-minute Water Table

DataTable (QuarterHourlyWater,1,-1)

DataInterval (0,15,Min,0)

Sample (1,StationID,fp2)

Sample (1,WaterHt1\_cm,FP2)

Average (1,WaterHt1\_cm,FP2,False)

Maximum (1,WaterHt1\_cm,FP2,False,False)

Minimum (1,WaterHt1\_cm,FP2,False,False)

Sample (1,WaterHt2\_cm,FP2)

Average (1,WaterHt2\_cm,FP2,False)

Maximum (1,WaterHt2\_cm,FP2,False,False)

Minimum (1,WaterHt2\_cm,FP2,False,False)

Sample (1,WaterHt1\_ft,FP2)

Average (1,WaterHt1\_ft,FP2,False)

Maximum (1,WaterHt1\_ft,FP2,False,False)

Minimum (1,WaterHt1\_ft,FP2,False,False)

Sample (1,WaterHt2\_ft,FP2)

Average (1,WaterHt2\_ft,FP2,False)

Maximum (1,WaterHt2\_ft,FP2,False,False)

Minimum (1,WaterHt2\_ft,FP2,False,False)

Average (1,WaterT1\_C,FP2,False)

Maximum (1,WaterT1\_C,FP2,False,False)

Minimum (1,WaterT1\_C,FP2,False,False)

Average (1,WaterT2\_C,FP2,False)

Maximum (1,WaterT2\_C,FP2,False,False)

Minimum (1,WaterT2\_C,FP2,False,False)

Sample (1,WaterHt1\_psi,FP2)

Average (1,WaterHt1\_psi,FP2,False)

Maximum (1,WaterHt1\_psi,FP2,False,False)

Minimum (1,WaterHt1\_psi,FP2,False,False)

Sample (1,WaterHt2\_psi,FP2)

Average (1,WaterHt2\_psi,FP2,False)

Maximum (1,WaterHt2\_psi,FP2,False,False)

Minimum (1,WaterHt2\_psi,FP2,False,False)

Average (5,WaterT\_C,FP2,False)

Maximum (5,WaterT\_C,FP2,False,False)

Minimum (5,WaterT\_C,FP2,False,False)

EndTable

'Hourly Diagnostics Table

DataTable (HourlyDiag,1,-1)

DataInterval (0,60,Min,0)

Sample (1,StationID,fp2)

'BATTERY VOLTS (V)

Sample (1,BattVolts\_V,FP2)

Average (1,BattVolts\_V,FP2,False)

Maximum (1,BattVolts\_V,FP2,False,False)

Minimum (1,BattVolts\_V,FP2,False,False)

'BATTERY CURRENT (A)

Sample (1,CH200\_M0(2),FP2)

Average (1,CH200\_M0(2),FP2,False)

Maximum (1,CH200\_M0(2),FP2,False,False)

Minimum (1,CH200\_M0(2),FP2,False,False)

'LOAD CURRENT (A)

Sample (1,CH200\_M0(3),FP2)

Average (1,CH200\_M0(3),FP2,False)

Maximum (1,CH200\_M0(3),FP2,False,False)

Minimum (1,CH200\_M0(3),FP2,False,False)

'SOLAR PANEL VOLTS (V)

Sample (1,CH200\_M0(4),FP2)

Average (1,CH200\_M0(4),FP2,False)

Maximum (1,CH200\_M0(4),FP2,False,False)

Minimum (1,CH200\_M0(4),FP2,False,False)

'SOLAR PANEL CURRENT (A)

Sample (1,CH200\_M0(5),FP2)

Average (1,CH200\_M0(5),FP2,False)

Maximum (1,CH200\_M0(5),FP2,False,False)

Minimum (1,CH200\_M0(5),FP2,False,False)

'Logger Temperature (deg C)

Average (1,LoggerTemp\_C,FP2,False)

'Charge Regulator Temperature (deg C)

Average (1,CH200\_M0(6),FP2,False)

EndTable

'Hourly Raw Measurements Table

DataTable (HourlyRaw,1,-1)

DataInterval (0,60,Min,0)  
Sample (1,StationID,fp2)

Sample (15,Therm\_kOhm(),FP2)  
Average (15,Therm\_kOhm(),FP2,False)  
EndTable

'Hourly Meteorological Measurements Table  
DataTable (Hourly,1,-1)  
DataInterval (0,60,Min,0)  
Sample (1,StationID,fp2)

Sample (3,AirT\_YSI1\_C,FP2)  
Average (3,AirT\_YSI1\_C,FP2,False)  
EndTable

'Hourly Subsurface Measurements Table  
DataTable (HrlySubs,1,-1)  
DataInterval (0,60,Min,0)  
Sample (1,StationID,fp2)

Sample (12,SoilT\_5cm\_C,FP2)  
Average (12,SoilT\_5cm\_C,FP2,False)  
EndTable

'Hourly Climate Table (for Current Conditions Table on Web)  
DataTable (HrlyClimate,1,96)  
DataInterval (0,60,Min,0)  
Sample (1,StationID,fp2)

Sample (1,AirT\_YSI1\_C,FP2)  
Sample (1,WaterT1\_C,FP2)  
Sample (1,WaterHt1\_ft,FP2)  
EndTable

'Daily Output Table  
DataTable (Daily,1,-1)  
DataInterval(0,1440,Min,0)  
Sample (1,StationID,fp2)

Average (3,AirT\_YSI1\_C,FP2,False)  
Maximum (3,AirT\_YSI1\_C,FP2,False,False)  
Minimum (3,AirT\_YSI1\_C,FP2,False,False)

Average (1,WaterHt1\_cm,FP2,False)  
Maximum (1,WaterHt1\_cm,FP2,False,False)

Minimum (1,WaterHt1\_cm,FP2,False,False)

Average (1,WaterHt2\_cm,FP2,False)

Maximum (1,WaterHt2\_cm,FP2,False,False)

Minimum (1,WaterHt2\_cm,FP2,False,False)

Average (1,WaterHt1\_ft,FP2,False)

Maximum (1,WaterHt1\_ft,FP2,False,False)

Minimum (1,WaterHt1\_ft,FP2,False,False)

Average (1,WaterHt2\_ft,FP2,False)

Maximum (1,WaterHt2\_ft,FP2,False,False)

Minimum (1,WaterHt2\_ft,FP2,False,False)

Average (1,WaterT1\_C,FP2,False)

Maximum (1,WaterT1\_C,FP2,False,False)

Minimum (1,WaterT1\_C,FP2,False,False)

Average (1,WaterT2\_C,FP2,False)

Maximum (1,WaterT2\_C,FP2,False,False)

Minimum (1,WaterT2\_C,FP2,False,False)

Average (1,WaterHt1\_psi,FP2,False)

Maximum (1,WaterHt1\_psi,FP2,False,False)

Minimum (1,WaterHt1\_psi,FP2,False,False)

Average (1,WaterHt2\_psi,FP2,False)

Maximum (1,WaterHt2\_psi,FP2,False,False)

Minimum (1,WaterHt2\_psi,FP2,False,False)

Average (5,WaterT\_C,FP2,False)

Maximum (5,WaterT\_C,FP2,False,False)

Minimum (5,WaterT\_C,FP2,False,False)

Average (12,SoilT\_5cm\_C,FP2,False)

EndTable

.....

"" MAIN PROGRAM ""

.....

'SCAN (EXECUTE) PROGRAM AT 60-SEC INTERVALS

BeginProg

Scan (60,Sec,0,0)

"" Set Station ID ""

StationID = ID



```

' get the real time into variables
RealTime (rTime)
' compute Minutes Into Day from hours and minutes into the hour.
MinIntoDay = (Hour * 60) + Minute

' initialize the default (power up) conditions
If Initialized = 0 Then
  NEWBATTCAP = 12 ' 100Ahr is max capacity the CH200 will accept

  IMAGERATE_MIN = 60
  IMAGE2RATE_MIN = 60

  STARTIMAGEMID = 0 ' 0
  STOPIMAGEMID = 1439 ' 1439
  CAMERAMANCONTROL = "off"
  CAMERADEFROSTERMANCONTROL = "off"
  CAMERADEFROSTERMODE = "manual"
  CAMERADEFROSTERONMID = 710 ' 710 = 11:50
  CAMERADEFROSTEROFFMID = 720 ' 720 = noon

  STARTIMAGE2MID = 0 ' 0
  STOPIMAGE2MID = 1439 ' 1439
  CAMERA2MANCONTROL = "off"
  CAMERA2DEFROSTERMANCONTROL = "off"
  CAMERA2DEFROSTERMODE = "manual"
  CAMERA2DEFROSTERONMID = 710 ' 710 = 11:50
  CAMERA2DEFROSTEROFFMID = 720 ' 720 = noon

  Initialized = 1
EndIf

.....
'   CC5MPXWD Camera #1 Image Trigger   '
.....
'   take an image every ImageRate_min between the Start and Stop times.
If MinIntoDay > STARTIMAGEMID AND MinIntoDay < STOPIMAGEMID AND
IfTime(0,IMAGERATE_MIN,Min) Then
  PulsePort (4,20000) ' 20,000 uSec = 20mSec pulse to trigger
EndIf
' OR take and image every time TakeImage is set to 1
If TAKEIMAGE = 1 Then
  PulsePort (4,20000) ' 20,000 uSec = 20mSec pulse to trigger
  TAKEIMAGE = 0
EndIf

```

```

'   CC5MPXWD Camera #2 Image Trigger   '
' take an image every ImageRate_min between the Start and Stop times.
' The second image is taken 1 minute into the Image Rate period
If MinIntoDay > STARTIMAGEMID AND MinIntoDay < STOPIMAGEMID AND IfTime
(1,IMAGE2RATE_MIN,Min) Then
  PulsePort (6,20000) ' 20,000 uSec = 20mSec pulse to trigger
EndIf
' OR take and image every time TakeImage is set to 1
If TAKEIMAGE2 = 1 Then
  PulsePort (6,20000) ' 20,000 uSec = 20mSec pulse to trigger
  TAKEIMAGE2 = 0
EndIf

' Diagnostics '

'MEASURE DATALOGGER WIRING PANEL TEMPERATURE (deg C)
PanelTemp (LoggerTemp_C,250)
' MEASURE DATALOGGER BATTERY VOLTS (V)
Battery (BattVolts_V)

' Feature to enter specific battery capacity as a Public value and send to charger(s)
' Get additional values from CH200
SDI12Recorder (CH200_MX(),1,0,"M6!",1.0,0)
' If the present battery capacity is not the same as the new battery capacity, send the new one.
If BattCap <> NEWBATTCAP Then
  SDI12command = "XC" & FormatFloat (NEWBATTCAP, "%4.1f") & "!"
  SDI12Recorder (SDI12result,1,0,SDI12command,1.0,0)
EndIf

' CH200 CHARGE REGULATOR MEASUREMENTS
' Connected to Control Port 1
' We will use the default address of 0.
SDI12Recorder (CH200_M0(),1,0,"MC!",1.0,0)

' Compute running Power and daily running total AmpHours/Day values for each current
measurement.
LoadPwr_W = CH200BattVolts_V * LoadCrnt_A
ChargePwr_W = SolarPanel_V * SolarPanel_A
' Divide each 1 minute Amp sample by 1440 sample/day so that the total at the end of the day
is to get avg current for the day
' then multiply by 24 Hr/day to get AHr/Day. or divide by 60 because 24/1440 = 1/60
' Separate and sum each the positive and negative currents into and out of the battery to get the
total AHr in/out for the day.
' Sample hourly and daily, then zero at end of the day.

```

If BattCrnt\_A > 0 Then DlyBatCrtIn\_AHr = DlyBatCrtIn\_AHr + BattCrnt\_A/60  
 If BattCrnt\_A < 0 Then DlyBatCrtOut\_AHr = DlyBatCrtOut\_AHr + BattCrnt\_A/60

```

.....
"   READ CSI SDI-12 CS450 water level/temp   "
.....
' There are two CSI CS450 SDI-12 vented water level pressure transducers.
' Sensor 1 is connected to Control Port 5, Sensor 2 is connected to Control Port 7
' We will use the defalut address of 0.
SDI12Recorder (CS450Data1(),5,0,"C!",1.0,0)
SDI12Recorder (CS450Data2(),7,0,"C!",1.0,0)

' convert water heights in psi to cm (70.307 cm/psi)
WaterHt1_cm = WaterHt1_psi * 70.307
WaterHt2_cm = WaterHt2_psi * 70.307

'Convert Water Height in cm to ft. (0.0328 ft/cm)
WaterHt1_ft = WaterHt1_cm * 0.0328
WaterHt2_ft = WaterHt2_cm * 0.0328

.....
""   READ 109 Water Temp Probes   ""
.....
Therm109 (WaterT_C(),5,12,Vx2,0,250,1.0,0)

.....
""   READ Thermistors           ""
.....

*****
"   READ AM16/32 #1 MULTIPLEXER   "
*****

PortSet (2 ,1 )   'TURN ON AM16/32 #1 MULTIPLEXER, SET PORT 2 HIGH
i = 1             'INITIALIZE INDEX INTERGER I TO ONE

SubScan (0,Sec,5)  'SCAN LOOP -- 5 ITERATIONS
'ADVANCE AM16/32 #1 GROUP BY 1, PULSE PORT 2 (10 ms delay)
PulsePort (3,10000)
'MEASURE GWS THERMISTORS, (Voltage Ratio X = Rs/(Rs+Rf))
BrHalf (therm(i),1,mV2500,1,Vx1,1,2500,True ,0,_60Hz,1.0,0)
i = i + 1
BrHalf (therm(i),1,mV2500,2,Vx1,1,2500,True ,0,_60Hz,1.0,0)
i = i + 1
BrHalf (therm(i),1,mV2500,3,Vx1,1,2500,True ,0,_60Hz,1.0,0)

```

```

i = i + 1
NextSubScan
PortSet (2,0)      'TURN OFF AM16/32 #1 MULTIPLEXER, SET PORT 2 LOW

```

'CONVERT MEASURED VOLTAGE RATIO TO RESISTANCE (kOHM) FOR 15 GWS THERMISTORS

```

For i=1 To 15
  Therm_kOhm(i) = Rf_1*therm(i)/(1-therm(i))
Next i

```

'CONVERT GWS THERMISTOR RESISTANCE TO deg C FOR 15 GWS THERMISTORS

```

For i=1 To 15
  D(i) = LN (1000*Therm_kOhm(i))           'ln resistance (ohm)
  TEMP_C(i) = (1/(a + b*D(i) + c*(D(i))^3)) - 273.15  'Steinhart & Hart Equation
Next i

```

.....

'Camera #1 control code:

.....

' The camera is turned Off at the top of the hour.

```

If IfTime (0,60,Min) Then
  CAMERAMANCONTROL = "off"
  CAMERADEFROSTERMANCONTROL = "off"
  'Turn camera off
  PortSet (4,0)
EndIf

```

'Camera On control. Turning camera On will take photo.

```

If CAMERAMANCONTROL = "on" Then
  PortSet (4,1 )
EndIf
'Turn camera Off if CameraManControl AND TurnDefrosterOn is false or off
If CAMERAMANCONTROL = "off" AND TurnDefrosterOn = false Then
  PortSet (4 ,0 )
EndIf

```

' Control CAMERA Defroster (aka Heat)

'CameraDefrosterMode has two states, manual and auto.

'If in manual, CameraDefrosterManControl turns the heat On.

' The camera's logic control turns the heat Off after 65 seconds unless turned back On.

'Enter On or Off in CameraDefrosterManControl to turn heaters On or Off.

'If in Auto, the heaters are turned on at CameraDefrosterOnMID and turned Off at CameraDefrosterOffMID.

' MID stands for Minutes Into the Day.

'The camera has its own heat control logic:



EndIf

.....

'Camera #2 control code:

.....

' The camera is turned Off at the top of the hour.

If IfTime (0,60,Min) Then

    CAMERA2MANCONTROL = "off"

    CAMERA2DEFROSTERMANCONTROL = "off"

    'Turn camera off

    PortSet (6,0)

EndIf

'Camera On control. Turning camera On will take photo.

If CAMERA2MANCONTROL = "on" Then

    PortSet (6,1 )

EndIf

'Turn camera Off if CameraManControl AND TurnDefrosterOn is false or off

If CAMERA2MANCONTROL = "off" AND TurnDefroster2On = false Then

    PortSet (6 ,0 )

EndIf

If CAMERA2DEFROSTERMODE = "manual" AND  
CAMERA2DEFROSTERMANCONTROL = "off" Then

    TurnDefroster2On = false

EndIf

If CAMERA2DEFROSTERMODE = "manual" AND  
CAMERA2DEFROSTERMANCONTROL = "on" Then

    TurnDefroster2On = true

EndIf

If CAMERA2DEFROSTERMODE = "auto" AND MinIntoDay >  
CAMERA2DEFROSTERONMID AND MinIntoDay < CAMERA2DEFROSTEROFFMID  
Then

    TurnDefroster2On = true

EndIf

If CAMERAEDEFROSTERMODE = "auto" AND MinIntoDay >  
CAMERA2DEFROSTEROFFMID Then

    TurnDefroster2On = false

EndIf

If CAMERA2DEFROSTERMODE = "auto" AND MinIntoDay <  
CAMERA2DEFROSTERONMID Then

    TurnDefroster2On = false



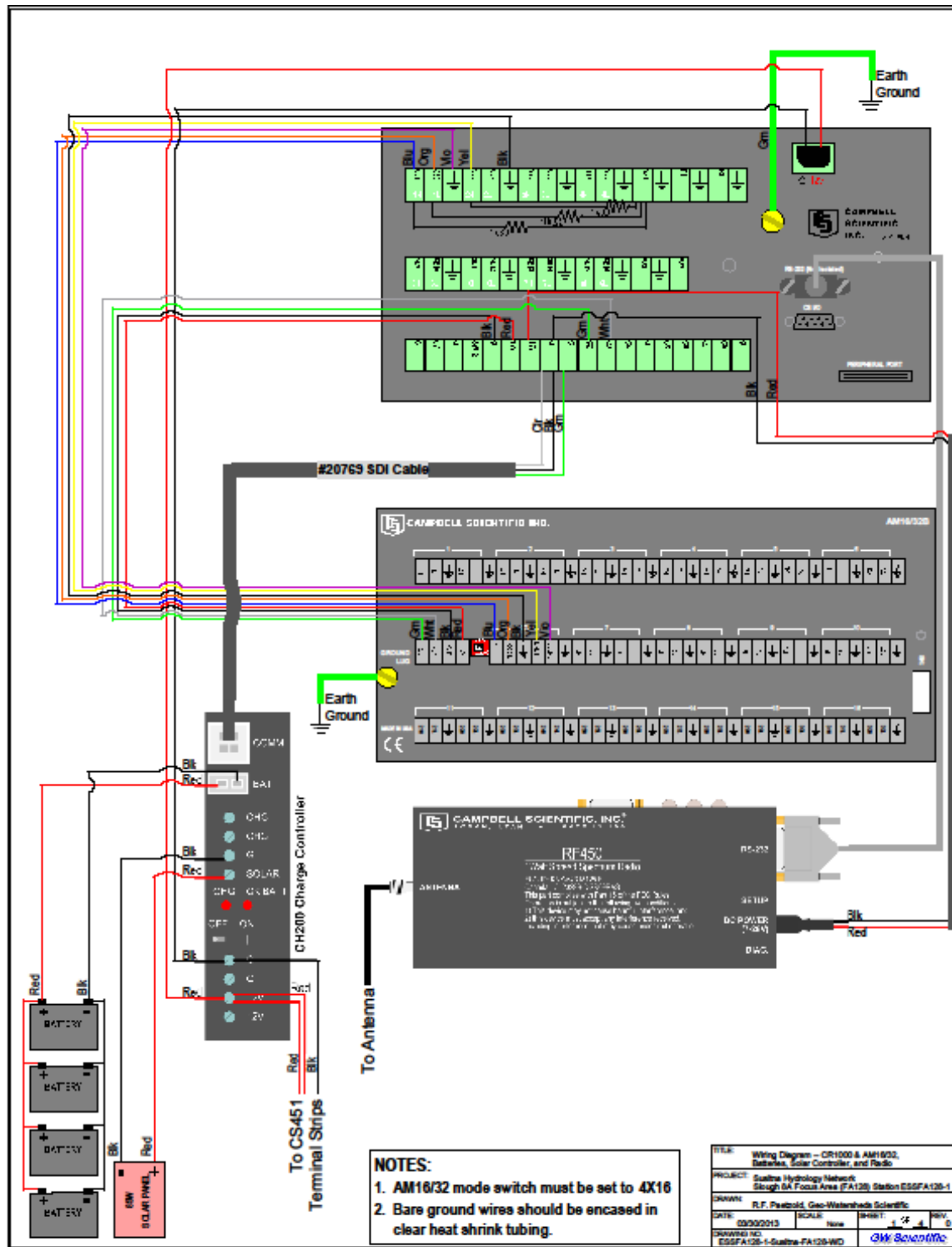


Figure C-2. ESSFA128-1 Sheet 1 (Data Logger, Power, Radio, Multiplexer).



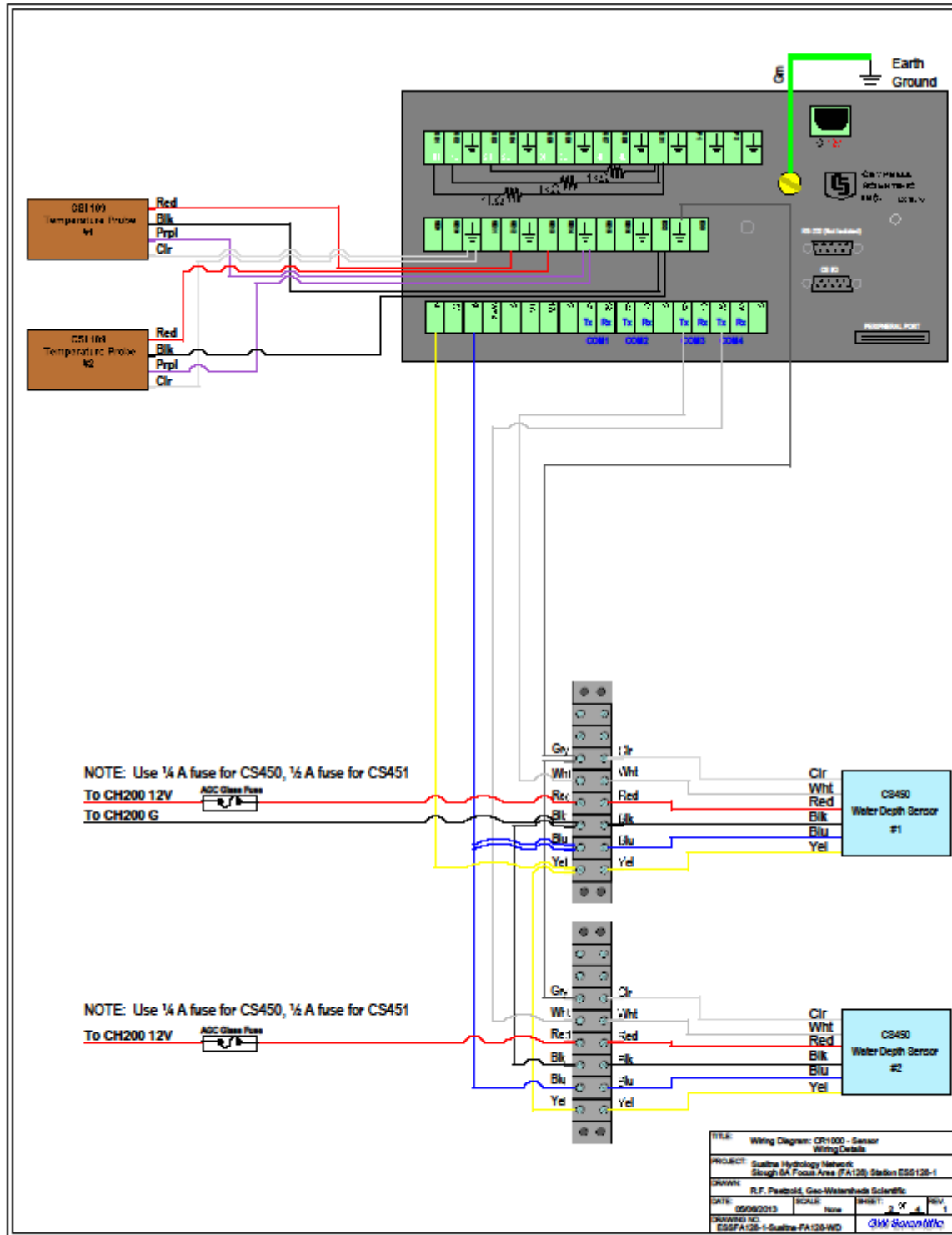


Figure C-3. ESSFA128-1 Sheet 2, rev. 1 (Data Logger, Sensors).

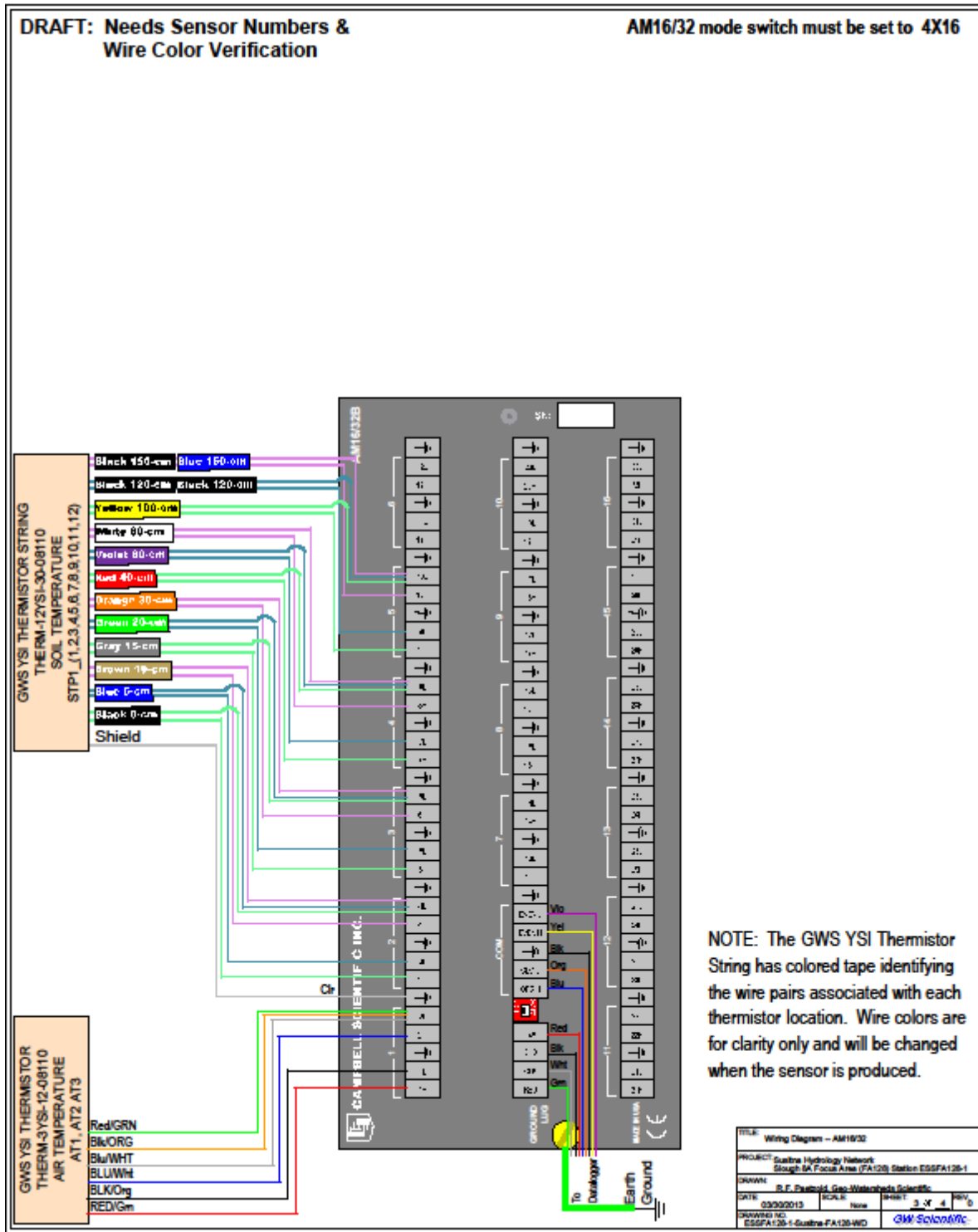


Figure C-4. ESSFA128-1 Sheet 3 (Multiplexer, Sensors).

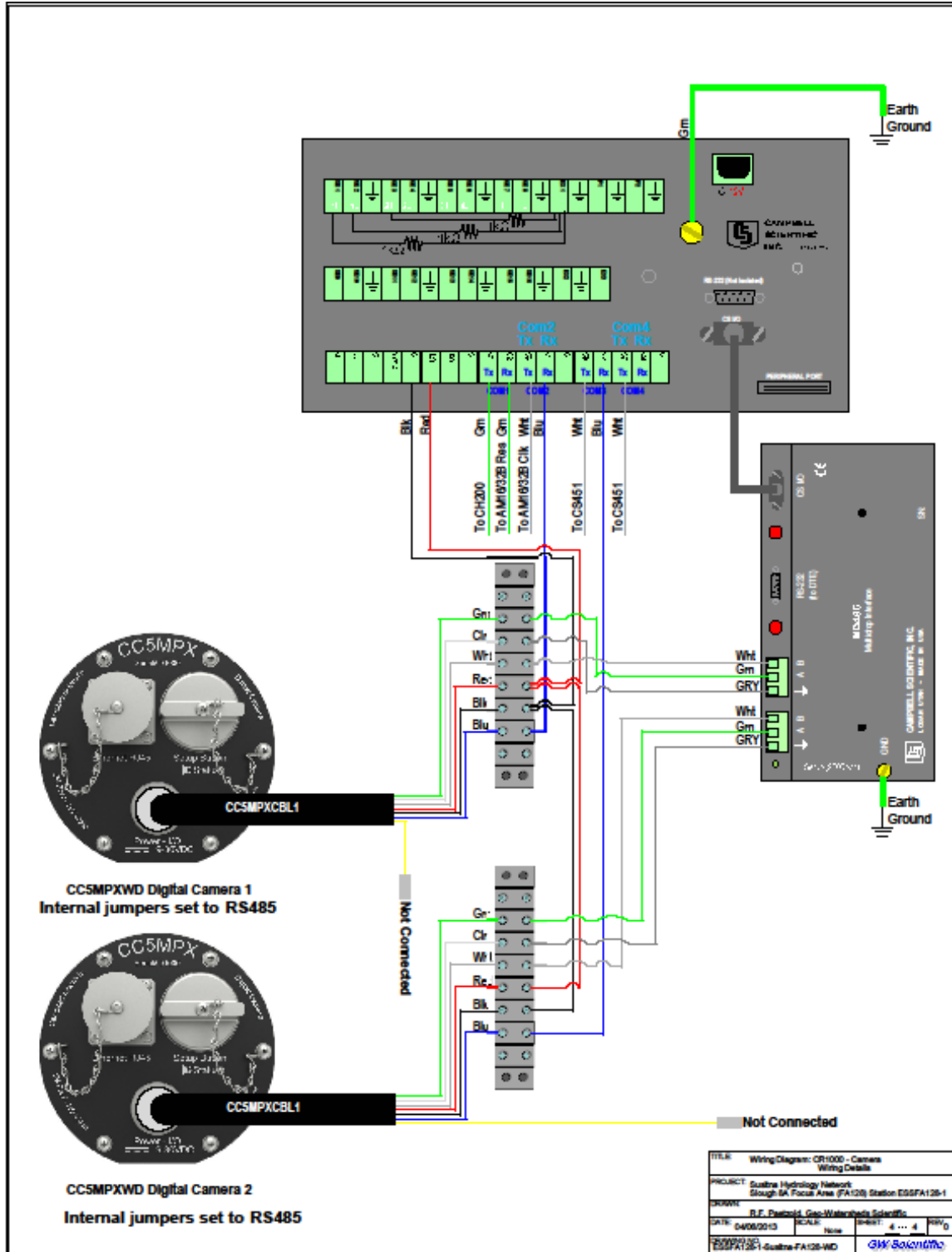


Figure C-5. ESSFA128-1 Sheet 4 (Data Logger, Cameras).

**The following program and wiring diagrams depict FA-104 (Whiskers Slough) station ESMF104-2, representative of the meteorological (CSI CR1000) type station:**

'CR1000 Series Datalogger

' Program name: ESMFA104-2\_130904.cr1

'Modification Of: ESMFA104-2\_130810.CR1

'Modified By: AMcHugh

'Date Modified: 08/10/13

'Modifications: Set WSpd2\_ms = 0 if < 0.45

' Old mods:

'Modifications: Increase SM from 4 to 6. Changed temperature string depth names.

'Modifications: Fixed precip over count.

'Station Notes:

' PakBus ID for Statino: 375 'INSERT PakBus ID HERE <=====

' Station ID: 375 'INSERT Station ID HERE <=====

' Time is set to AK Standard Time

.....

"" INDIVIDUAL STATION INPUTS ""

.....

'INSERT Station Name HERE:

StationName (ESMFA104-2) 'INSERT Station Name HERE

<=====

'INSERT Station ID HERE:

Const ID = 375 'INSERT Station ID HERE

<=====

'NR Lite2 s/n 134704 sens 13.9 uV/W/m2 1000(mV/uV)/13.9(uV/W/m2) = 71.942 W/m2 / mV

Const NR = 71.942 'NR Lite2 calibration constant HERE

<=====

' HFP01-15 s/n 8364 sens 61.15 uV/W/m2 1000/61.15 = 16.353

Const SHF = 16.353 ' Hukseflux HFP calibration constant HERE

<=====

'FIXED RESISTOR VALUE FOR GWS THERMISTOR CIRCUITS

Const Rf = 1.0 'FIXED RESISTOR 1 (kOHM) HERE

' For YSI thermistors -- conversion of kOHM to deg C

Const a = 0.0014654354

Const b = 0.0002386780

Const c = 0.0000001000

## 'DECLARE PUBLIC VARIABLES

PreserveVariables ' variables are maintained over reboot.

Public StationID ' Station ID number, USER INPUT

Public NR\_CalCoef

Public SHF\_CalCoef

Public BattVolts\_V

Public LoggerTemp\_C

Public DlyBatCrtIn\_AHr, DlyBatCrtOut\_AHr

Public LoadPwr\_W, ChargePwr\_W

Public CH200\_M0(9) 'Array to hold all data from CH200

Public CH200\_MX(4) ' Array to hold extended data from CH200

Alias CH200\_MX(1) = BattTargV ' Battery charging target voltage

Alias CH200\_MX(2) = DgtlPotSet ' Digital potentiometer setting

Alias CH200\_MX(3) = BattCap ' Present battery capacity

Alias CH200\_MX(4) = Qloss ' Battery charge deficit

' SDI-12 formatted battery capacity value

Public SDI12command As String

' Response from CH200. Retrns the address of the unit and "ok" if all went well

Public SDI12result As String

Public NEWBATTCAP ' the new battery capacity if you need to change it.

Public AirTemp\_C, RH, DewPoint\_C, AirTemp\_F

Public PT1Data(2) 'Water Level Sensor 1 - pressure, temperature

Public WaterHt1\_cm, WaterHt1\_ft ' Water level above the probe

Public SMADData(6),SMBData(6),SMCData(6),SMDDData(6),SMEDData(6),SMFDData(6)

Public BaroPrNC\_mB

Public Rain\_mm

Public WSpd\_ms, WDir, WSpd\_mph

Public WSpd2\_ms

Public WindChill\_C, WindChill\_F

Public VPdef\_kPa, VPsat\_kPa, VPact\_kPa 'kPa

Public SolRad\_W\_m2

Public NetRad\_mV, NetRad\_W\_m2, NetRadWindCorr\_W\_m2

Public SHF\_W\_m2, SHF\_mV

Public Therm\_kOhm(15), Temp\_C(15)

Dim therm(15),D(15),i,j

Dim Initialized

## Dim TwoMinWind

Alias SMADData(1) = SM\_A\_VV  
Alias SMADData(2) = SM\_A\_EC\_dS\_m  
Alias SMADData(3) = SM\_A\_T\_C  
Alias SMADData(4) = SM\_A\_Perm  
Alias SMADData(5) = SM\_A\_Per\_uS  
Alias SMADData(6) = SM\_A\_VR

Alias SMBData(1) = SM\_B\_VV  
Alias SMBData(2) = SM\_B\_EC\_dS\_m  
Alias SMBData(3) = SM\_B\_T\_C  
Alias SMBData(4) = SM\_B\_Perm  
Alias SMBData(5) = SM\_B\_Per\_uS  
Alias SMBData(6) = SM\_B\_VR

Alias SMCDData(1) = SM\_C\_VV  
Alias SMCDData(2) = SM\_C\_EC\_dS\_m  
Alias SMCDData(3) = SM\_C\_T\_C  
Alias SMCDData(4) = SM\_C\_Perm  
Alias SMCDData(5) = SM\_C\_Per\_uS  
Alias SMCDData(6) = SM\_C\_VR

Alias SMDDData(1) = SM\_D\_VV  
Alias SMDDData(2) = SM\_D\_EC\_dS\_m  
Alias SMDDData(3) = SM\_D\_T\_C  
Alias SMDDData(4) = SM\_D\_Perm  
Alias SMDDData(5) = SM\_D\_Per\_uS  
Alias SMDDData(6) = SM\_D\_VR

Alias SMEDData(1) = SM\_E\_VV  
Alias SMEDData(2) = SM\_E\_EC\_dS\_m  
Alias SMEDData(3) = SM\_E\_T\_C  
Alias SMEDData(4) = SM\_E\_Perm  
Alias SMEDData(5) = SM\_E\_Per\_uS  
Alias SMEDData(6) = SM\_E\_VR

Alias SMFData(1) = SM\_F\_VV  
Alias SMFData(2) = SM\_F\_EC\_dS\_m  
Alias SMFData(3) = SM\_F\_T\_C  
Alias SMFData(4) = SM\_F\_Perm  
Alias SMFData(5) = SM\_F\_Per\_uS  
Alias SMFData(6) = SM\_F\_VR

Alias PT1Data(1) = WaterHt1\_psi  
Alias PT1Data(2) = WaterT1\_C

Alias CH200\_M0(1)=CH200BattVolts\_V 'Battery voltage: VDC  
 Alias CH200\_M0(2)=BattCrnt\_A 'Current going into, or out of, the battery: Amps  
 Alias CH200\_M0(3)=LoadCrnt\_A 'Current going to the load: Amps  
 Alias CH200\_M0(4)=SolarPanel\_V 'Voltage coming into the charger: VDC  
 Alias CH200\_M0(5)=SolarPanel\_A 'Current coming into the charger: Amps  
 Alias CH200\_M0(6)=Chgr\_Tmp\_C 'Charger temperature: Celsius  
 Alias CH200\_M0(7)=Chgr\_State 'Charging state: 2=Cycle, 3=Float, 1=Current Limited, or  
 0=None  
 Alias CH200\_M0(8)=Chgr\_Source 'Charging source: 0=None, 1=Solar, or 2=AC  
 Alias CH200\_M0(9)=Ck\_Batt 'Check battery error: 0=normal, 1=check battery

Alias Temp\_C(1) = AirT\_YSI1\_C  
 Alias Temp\_C(2) = AirT\_YSI2\_C  
 Alias Temp\_C(3) = AirT\_YSI3\_C

Alias Temp\_C(4) = SoilT\_5cm\_C  
 Alias Temp\_C(5) = SoilT\_10cm\_C  
 Alias Temp\_C(6) = SoilT\_15cm\_C  
 Alias Temp\_C(7) = SoilT\_20cm\_C  
 Alias Temp\_C(8) = SoilT\_30cm\_C  
 Alias Temp\_C(9) = SoilT\_40cm\_C  
 Alias Temp\_C(10) = SoilT\_50cm\_C  
 Alias Temp\_C(11) = SoilT\_60cm\_C  
 Alias Temp\_C(12) = SoilT\_80cm\_C  
 Alias Temp\_C(13) = SoilT\_100cm\_C  
 Alias Temp\_C(14) = SoilT\_120cm\_C  
 Alias Temp\_C(15) = SoilT\_150cm\_C

#### 'Hourly Diagnostics Table

DataTable (HourlyDiag,1,-1)  
 DataInterval (0,60,Min,0)  
 Sample (1,StationID,fp2)

#### 'BATTERY VOLTS (V)

Sample (1,BattVolts\_V,FP2)  
 Average (1,BattVolts\_V,FP2,False)  
 Maximum (1,BattVolts\_V,FP2,False,False)  
 Minimum (1,BattVolts\_V,FP2,False,False)

#### 'BATTERY CURRENT (A)

Sample (1,CH200\_M0(2),FP2)  
 Average (1,CH200\_M0(2),FP2,False)  
 Maximum (1,CH200\_M0(2),FP2,False,False)  
 Minimum (1,CH200\_M0(2),FP2,False,False)

'LOAD CURRENT (A)

Sample (1,CH200\_M0(3),FP2)

Average (1,CH200\_M0(3),FP2,False)

Maximum (1,CH200\_M0(3),FP2,False,False)

Minimum (1,CH200\_M0(3),FP2,False,False)

'SOLAR PANEL VOLTS (V)

Sample (1,CH200\_M0(4),FP2)

Average (1,CH200\_M0(4),FP2,False)

Maximum (1,CH200\_M0(4),FP2,False,False)

Minimum (1,CH200\_M0(4),FP2,False,False)

'SOLAR PANEL CURRENT (A)

Sample (1,CH200\_M0(5),FP2)

Average (1,CH200\_M0(5),FP2,False)

Maximum (1,CH200\_M0(5),FP2,False,False)

Minimum (1,CH200\_M0(5),FP2,False,False)

Average (1,LoggerTemp\_C,FP2,False) 'Logger Temperature (deg C)

Average (1,CH200\_M0(6),FP2,False) 'Charge Regulator Temperature (deg C)

Sample (1,NEWBATTCAP,FP2)

Sample (1,BattCap,FP2)

Sample (1,DlyBatCrtIn\_AHr,FP2)

Sample (1,DlyBatCrtOut\_AHr,FP2)

Average (1,ChargePwr\_W,FP2,False)

Maximum (1,ChargePwr\_W,FP2,False,False)

Minimum (1,ChargePwr\_W,FP2,False,False)

Average (1,LoadPwr\_W,FP2,False)

Maximum (1,LoadPwr\_W,FP2,False,False)

Minimum (1,LoadPwr\_W,FP2,False,False)

'Charger state

Sample (1,CH200\_M0(7),FP2)

EndTable

'Hourly Meteorological Measurements Table

DataTable (Hourly,1,-1)

DataInterval (0,60,Min,0)

Sample (1,StationID,fp2)

Sample (3,AirT\_YSI1\_C,FP2)

Average (3,AirT\_YSI1\_C,FP2,False)



Maximum (3,AirT\_YSI1\_C,FP2,False,False)  
Minimum (3,AirT\_YSI1\_C,FP2,False,False)

Sample (1,AirTemp\_C,FP2)  
Average (1,AirTemp\_C,FP2,False)  
Maximum (1,AirTemp\_C,FP2,False,False)  
Minimum (1,AirTemp\_C,FP2,False,False)

Sample (1,RH,FP2)  
Average (1,RH,FP2,False)  
Maximum (1,RH,FP2,False,False)  
Minimum (1,RH,FP2,False,False)

Sample (1,DewPoint\_C,FP2)  
Average (1,DewPoint\_C,FP2,False)  
Maximum (1,DewPoint\_C,FP2,False,False)  
Minimum (1,DewPoint\_C,FP2,False,False)

Sample (1,VPact\_kPa,FP2)  
Average (1,VPact\_kPa,FP2,False)  
Maximum (1,VPact\_kPa,FP2,False,False)  
Minimum (1,VPact\_kPa,FP2,False,False)

Sample (1,VPsat\_kPa,FP2)  
Average (1,VPsat\_kPa,FP2,False)  
Maximum (1,VPsat\_kPa,FP2,False,False)  
Minimum (1,VPsat\_kPa,FP2,False,False)

Sample (1,VPdef\_kPa,FP2)  
Average (1,VPdef\_kPa,FP2,False)  
Maximum (1,VPdef\_kPa,FP2,False,False)  
Minimum (1,VPdef\_kPa,FP2,False,False)

Sample (1,WSpd\_ms,FP2)  
Sample (1,WDir,FP2)  
WindVector (1,WSpd\_ms,WDir,FP2,False,0,0,0)  
Maximum (1,WSpd\_ms,FP2,False,False)

Sample (1,WSpd2\_ms,FP2)  
Average (1,WSpd2\_ms,FP2,False)  
Maximum (1,WSpd2\_ms,FP2,False,False)

Sample (1,WindChill\_C,FP2)  
Average (1,WindChill\_C,FP2,False)  
Maximum (1,WindChill\_C,FP2,False,False)  
Minimum (1,WindChill\_C,FP2,False,False)

Sample (1,SolRad\_W\_m2,FP2)  
Average (1,SolRad\_W\_m2,FP2,False)

Sample (1,NetRad\_W\_m2,FP2)  
Average (1,NetRad\_W\_m2,FP2,False)

Sample (1,NetRadWindCorr\_W\_m2,FP2)  
Average (1,NetRadWindCorr\_W\_m2,FP2,False)

Totalize (1,Rain\_mm,FP2,False)

Sample (1,BaroPrNC\_mB,FP2)  
EndTable

'15-Min Meteorological Measurements Table  
DataTable (QuarterHrlyMet,1,-1)  
DataInterval (0,15,Min,0)  
Sample (1,StationID,fp2)

Sample (3,AirT\_YSI1\_C,FP2)  
Average (3,AirT\_YSI1\_C,FP2,False)  
Maximum (3,AirT\_YSI1\_C,FP2,False,False)  
Minimum (3,AirT\_YSI1\_C,FP2,False,False)

Sample (1,AirTemp\_C,FP2)  
Average (1,AirTemp\_C,FP2,False)  
Maximum (1,AirTemp\_C,FP2,False,False)  
Minimum (1,AirTemp\_C,FP2,False,False)

Sample (1,RH,FP2)  
Average (1,RH,FP2,False)  
Maximum (1,RH,FP2,False,False)  
Minimum (1,RH,FP2,False,False)

Sample (1,DewPoint\_C,FP2)  
Average (1,DewPoint\_C,FP2,False)  
Maximum (1,DewPoint\_C,FP2,False,False)  
Minimum (1,DewPoint\_C,FP2,False,False)

Sample (1,VPact\_kPa,FP2)  
Average (1,VPact\_kPa,FP2,False)  
Maximum (1,VPact\_kPa,FP2,False,False)  
Minimum (1,VPact\_kPa,FP2,False,False)

Sample (1,VPsat\_kPa,FP2)

Average (1,VPsat\_kPa,FP2,False)  
Maximum (1,VPsat\_kPa,FP2,False,False)  
Minimum (1,VPsat\_kPa,FP2,False,False)

Sample (1,VPdef\_kPa,FP2)  
Average (1,VPdef\_kPa,FP2,False)  
Maximum (1,VPdef\_kPa,FP2,False,False)  
Minimum (1,VPdef\_kPa,FP2,False,False)

Sample (1,WSpd\_ms,FP2)  
Sample (1,WDir,FP2)  
WindVector (1,WSpd\_ms,WDir,FP2,False,0,0,0)  
Maximum (1,WSpd\_ms,FP2,False,False)

Sample (1,WSpd2\_ms,FP2)  
Average (1,WSpd2\_ms,FP2,False)  
Maximum (1,WSpd2\_ms,FP2,False,False)

Sample (1,WindChill\_C,FP2)  
Average (1,WindChill\_C,FP2,False)  
Maximum (1,WindChill\_C,FP2,False,False)  
Minimum (1,WindChill\_C,FP2,False,False)

Sample (1,SolRad\_W\_m2,FP2)  
Average (1,SolRad\_W\_m2,FP2,False)

Sample (1,NetRad\_W\_m2,FP2)  
Average (1,NetRad\_W\_m2,FP2,False)

Sample (1,NetRadWindCorr\_W\_m2,FP2)  
Average (1,NetRadWindCorr\_W\_m2,FP2,False)

Totalize (1,Rain\_mm,FP2,False)

Sample (1,BaroPrNC\_mB,FP2)  
EndTable

2-min Wind Table  
DataTable (TwoMinWd,1,1440)  
DataInterval (0,2,Min,0)  
Sample (1,StationID,fp2)

WindVector (1,WSpd\_ms,WDir,FP2,False,0,0,0)  
Maximum (1,WSpd\_ms,FP2,False,False)

Average (1,WSpd2\_ms,FP2,False)

Maximum (1,WSpd2\_ms,FP2,False,False)  
EndTable

'15-minute Water Ttable

DataTable (QuarterHourlyWater,1,-1)  
DataInterval(0,15,Min,0)  
Sample (1,StationID,fp2)

Sample (1,WaterHt1\_cm,FP2)  
Average (1,WaterHt1\_cm,FP2,False)  
Maximum (1,WaterHt1\_cm,FP2,False,False)  
Minimum (1,WaterHt1\_cm,FP2,False,False)

Sample (1,WaterHt1\_ft,FP2)  
Average (1,WaterHt1\_ft,FP2,False)  
Maximum (1,WaterHt1\_ft,FP2,False,False)  
Minimum (1,WaterHt1\_ft,FP2,False,False)

Sample (1,WaterT1\_C,FP2)  
Average (1,WaterT1\_C,FP2,False)  
Maximum (1,WaterT1\_C,FP2,False,False)  
Minimum (1,WaterT1\_C,FP2,False,False)

Sample (1,WaterHt1\_psi,FP2)  
Average (1,WaterHt1\_psi,FP2,False)  
Maximum (1,WaterHt1\_psi,FP2,False,False)  
Minimum (1,WaterHt1\_psi,FP2,False,False)  
EndTable

' Hourly Raw Table

DataTable (HourlyRaw,1,-1)  
DataInterval(0,60,Min,0)  
Sample (1,StationID,fp2)

Sample (1,NR\_CalCoef,FP2)  
Sample (1,SHF\_CalCoef,FP2)

Sample (15,Therm\_kOhm(),FP2)  
Average (15,Therm\_kOhm(),FP2,False)

Sample (6,SM\_A\_Per\_uS,FP2)  
Average (6,SM\_A\_Per\_uS,FP2,False)

Sample (1,SHF\_mV,FP2)  
Average (1,SHF\_mV,FP2,False)  
EndTable

## 'Daily Output Table

DataTable (Daily,1,-1)

DataInterval(0,1440,Min,0)

Sample (1,StationID,fp2)

Average (3,AirT\_YSI1\_C,FP2,False)

Maximum (3,AirT\_YSI1\_C,FP2,False,False)

Minimum (3,AirT\_YSI1\_C,FP2,False,False)

Average (1,AirTemp\_C,FP2,False)

Maximum (1,AirTemp\_C,FP2,False,False)

Minimum (1,AirTemp\_C,,FP2,False,False)

Maximum (1,RH,FP2,False,False)

Minimum (1,RH,FP2,False,False)

Maximum (1,DewPoint\_C,FP2,False,False)

Minimum (1,DewPoint\_C,,FP2,False,False)

Maximum (1,VPact\_kPa,FP2,False,False)

Minimum (1,VPact\_kPa,,FP2,False,False)

Maximum (1,VPsat\_kPa,FP2,False,False)

Minimum (1,VPsat\_kPa,,FP2,False,False)

Maximum (1,VPdef\_kPa,FP2,False,False)

Minimum (1,VPdef\_kPa,,FP2,False,False)

WindVector (1,WSpd\_ms,WDir,FP2,False,0,0,0)

Maximum (1,WSpd\_ms,FP2,False,False)

Average (1,WSpd2\_ms,FP2,False)

Maximum (1,WSpd2\_ms,FP2,False,False)

Maximum (1,WindChill\_C,FP2,False,False)

Minimum (1,WindChill\_C,,FP2,False,False)

Average (1,SolRad\_W\_m2,FP2,False)

Average (1,NetRad\_W\_m2,FP2,False)

Average (1,NetRadWindCorr\_W\_m2,FP2,False)

Totalize (1,Rain\_mm,FP2,False)

Average (1,SM\_A\_VV,FP2,False)

Average (1,SM\_B\_VV,FP2,False)

Average (1,SM\_C\_VV,FP2,False)  
 Average (1,SM\_D\_VV,FP2,False)  
 Average (1,SM\_E\_VV,FP2,False)  
 Average (1,SM\_F\_VV,FP2,False)

Average (1,SM\_A\_T\_C,FP2,False)  
 Average (1,SM\_B\_T\_C,FP2,False)  
 Average (1,SM\_C\_T\_C,FP2,False)  
 Average (1,SM\_D\_T\_C,FP2,False)  
 Average (1,SM\_E\_T\_C,FP2,False)  
 Average (1,SM\_F\_T\_C,FP2,False)

Average (1,SM\_A\_EC\_dS\_m,FP2,False)  
 Average (1,SM\_B\_EC\_dS\_m,FP2,False)  
 Average (1,SM\_C\_EC\_dS\_m,FP2,False)  
 Average (1,SM\_D\_EC\_dS\_m,FP2,False)  
 Average (1,SM\_E\_EC\_dS\_m,FP2,False)  
 Average (1,SM\_F\_EC\_dS\_m,FP2,False)

Average (12,SoilT\_5cm\_C,FP2,False)

Average (1,SHF\_W\_m2,FP2,False)

Average (1,WaterHt1\_cm,FP2,False)  
 Maximum (1,WaterHt1\_cm,FP2,False,False)  
 Minimum (1,WaterHt1\_cm,FP2,False,False)

Average (1,WaterHt1\_ft,FP2,False)  
 Maximum (1,WaterHt1\_ft,FP2,False,False)  
 Minimum (1,WaterHt1\_ft,FP2,False,False)

Average (1,WaterT1\_C,FP2,False)  
 Maximum (1,WaterT1\_C,FP2,False,False)  
 Minimum (1,WaterT1\_C,FP2,False,False)

Average (1,WaterHt1\_psi,FP2,False)  
 Maximum (1,WaterHt1\_psi,FP2,False,False)  
 Minimum (1,WaterHt1\_psi,FP2,False,False)  
 EndTable

'Hourly Climate Table (for Current Conditions Table on Web)

' Size limited to 96 data values or 4 days worth.

DataTable (HrlyClimate,1,96)

DataInterval (0,60,Min,0)

Sample (1,StationID,fp2)

Sample (3,AirT\_YSI1\_C,FP2)  
Sample (1,AirTemp\_C,FP2)  
Sample (1,WaterHt1\_cm,FP2)  
Sample (1,WaterHt1\_ft,FP2)  
Sample (1,WaterT1\_C,FP2)  
Sample (1,WaterHt1\_psi,FP2)  
Sample (1,RH,FP2)  
Sample (1,DewPoint\_C,FP2)  
Sample (1,WSpd\_ms,FP2)  
Sample (1,WDir,FP2)  
Sample (1,WSpd2\_ms,FP2)  
Sample (1,WindChill\_C,FP2)  
Sample (1,SolRad\_W\_m2,FP2)  
Sample (1,NetRad\_W\_m2,FP2)  
Sample (1,NetRadWindCorr\_W\_m2,FP2)  
Totalize (1,Rain\_mm,FP2,False)

Sample (1,SM\_A\_VV,FP2)  
Sample (1,SM\_B\_VV,FP2)  
Sample (1,SM\_C\_VV,FP2)  
Sample (1,SM\_D\_VV,FP2)  
Sample (1,SM\_E\_VV,FP2)  
Sample (1,SM\_F\_VV,FP2)

Sample (1,SM\_A\_T\_C,FP2)  
Sample (1,SM\_B\_T\_C,FP2)  
Sample (1,SM\_C\_T\_C,FP2)  
Sample (1,SM\_D\_T\_C,FP2)  
Sample (1,SM\_E\_T\_C,FP2)  
Sample (1,SM\_F\_T\_C,FP2)

Sample (1,SM\_A\_EC\_dS\_m,FP2)  
Sample (1,SM\_B\_EC\_dS\_m,FP2)  
Sample (1,SM\_C\_EC\_dS\_m,FP2)  
Sample (1,SM\_D\_EC\_dS\_m,FP2)  
Sample (1,SM\_E\_EC\_dS\_m,FP2)  
Sample (1,SM\_F\_EC\_dS\_m,FP2)

Sample (12,SoilT\_5cm\_C,FP2)

Sample (1,SHF\_W\_m2,FP2)  
Sample (1,BaroPrNC\_mB,FP2)  
EndTable

'Hourly Sub Surface Table

DataTable (HourlySubs,1,-1)

DataInterval (0,60,Min,0)

Sample (1,StationID,fp2)

Sample (1,SM\_A\_VV,FP2)

Sample (1,SM\_B\_VV,FP2)

Sample (1,SM\_C\_VV,FP2)

Sample (1,SM\_D\_VV,FP2)

Sample (1,SM\_E\_VV,FP2)

Sample (1,SM\_F\_VV,FP2)

Sample (1,SM\_A\_T\_C,FP2)

Sample (1,SM\_B\_T\_C,FP2)

Sample (1,SM\_C\_T\_C,FP2)

Sample (1,SM\_D\_T\_C,FP2)

Sample (1,SM\_E\_T\_C,FP2)

Sample (1,SM\_F\_T\_C,FP2)

Sample (1,SM\_A\_EC\_dS\_m,FP2)

Sample (1,SM\_B\_EC\_dS\_m,FP2)

Sample (1,SM\_C\_EC\_dS\_m,FP2)

Sample (1,SM\_D\_EC\_dS\_m,FP2)

Sample (1,SM\_E\_EC\_dS\_m,FP2)

Sample (1,SM\_F\_EC\_dS\_m,FP2)

Sample (12,SoilT\_5cm\_C,FP2)

Average (12,SoilT\_5cm\_C,FP2,False)

Sample (1,SHF\_W\_m2,FP2)

EndTable

\*\*\*\*\*

"" MAIN PROGRAM ""

\*\*\*\*\*

'SCAN (EXECUTE) PROGRAM AT 5-SEC INTERVALS

BeginProg

'Three-second scan interval

Scan (3,Sec,0,0)

"" Set Station ID ""

StationID = ID

NR\_CalCoef = NR

SHF\_CalCoef = SHF



```

' initialize the default (power up) conditions
If Initialized = 0 Then
  Initialized = 1
  NEWBATTCAP = 12 ' 100Ahr is max capacity the CH200 will accept
EndIf

"" READ RM YOUNG 05106 WIND MONITOR ""
PulseCount (WSpd_ms,1,1,1,1,.098,0)           'Wind Speed (m/s)
BrHalf(WDir,1,mV2500,8,Vx3,1,2500,true,200,250,355,0)  'Wind Direction (deg)

"""" Read 014A Wind Speed sensor in m/s """"
' M = 0.800 for m/s; O = 0.447
PulseCount (WSpd2_ms,1,2,2,1,0.800,0.447)

If WSpd2_ms < 0.45 Then
  WSpd2_ms =0
EndIf

"""" Measure TE525MM Precip Gage in mm to C4, Other lead to 5V.
PulseCount (Rain_mm,1,14,2,0,0.1,0)

'Begin 60-sec Loop
If IfTime (0,60,Sec) Then

  """""" MEASURE DATALOGGER WIRING PANEL TEMPERATURE (deg C)
  PanelTemp (LoggerTemp_C,250)

  """""" MEASURE DATALOGGER BATTERY VOLTS (V)
  Battery (BattVolts_V)

  ' Feature to enter specific battery capacity as a Public value and send to charger(s)
  'Get additional values from CH200
  SDI12Recorder (CH200_MX(),1,0,"M6!",1.0,0)
  'If the present battery capacity isnot the same as the new battery capacity, send the new one.
  If BattCap <> NEWBATTCAP Then
    SDI12command = "XC" & FormatFloat (NEWBATTCAP, "%4.1f") & "!"
    SDI12Recorder (SDI12result,1,0,SDI12command,1.0,0)
  EndIf

  """""" CH200 CHARGE REGULATOR MEASUREMENTS
  SDI12Recorder (CH200_M0(),1,0,"MC!",1.0,0)

  ' Compute running Power and daily running total AmpHours/Day values for each current
  measurement.
  LoadPwr_W = CH200BattVolts_V * LoadCrnt_A

```

```

ChargePwr_W = SolarPanel_V *SolarPanel_A
' Divide each 1 minute Amp sample by 1440 sample/day so that the total at the end of the day
is to get avg current for the day
' then muliPLY be 24 Hr/day to get AHr/Day. or divide by 60 because 24/1440 = 1/60
' Separate and sum each the positive and negative currents into and out of the battery to get
the total AHr in/out for the day.
' Sample hourly and daily, then zero at end of the day.

```

```

If BattCrnt_A > 0 Then DlyBatCrntIn_AHr = DlyBatCrntIn_AHr + BattCrnt_A/60
If BattCrnt_A < 0 Then DlyBatCrntOut_AHr = DlyBatCrntOut_AHr + BattCrnt_A/60

```

```

***** READ INW or CSI SDI-12 Pressure Transducer
SDI12Recorder (PT1Data(),5,1,"M!",1.0,0)
' convert water heights in psi to cm (70.307 cm/psi)
WaterHt1_cm = WaterHt1_psi * 70.307
'Convert Water Height in cm to ft. (0.0328 ft/cm)
WaterHt1_ft = WaterHt1_cm * 0.0328

```

```

***** Read 4 CS650 Soil Moisutire probes.
SDI12Recorder (SMADData(),5,"A","M3!",1.0,0)
SDI12Recorder (SMBData(),5,"B","M3!",1.0,0)
SDI12Recorder (SMCData(),5,"C","M3!",1.0,0)
SDI12Recorder (SMDDData(),5,"D","M3!",1.0,0)
SDI12Recorder (SMEDData(),5,"E","M3!",1.0,0)
SDI12Recorder (SMFData(),5,"F","M3!",1.0,0)

```

```

***** Measure Net Radiation NR Lite in W/m2
VoltDiff(NetRad_mV,1,mv25,5,True,0,_60Hz,1,0)
NetRad_W_m2 = NetRad_mV * NR_CalCoef
' Correct for wind if more than 5 m/s
If WSpd_ms >=5 Then
  NetRadWindCorr_W_m2 = NetRad_W_m2 *(1+0.021286*(WSpd_ms-5))
Else
  NetRadWindCorr_W_m2 = NetRad_W_m2
EndIf

```

```

***** Measure Hukseflux Heat Flux Plate
VoltDiff (SHF_mV,1,mV7_5,6,True,0,_60Hz,1.0,0)
SHF_W_m2 = SHF_mV * SHF_CalCoef

```

```

***** READ HC2S3 AIR TEMPERATURE/RELATIVE HUMIDITY SENSOR
' HC2S3 Air T/RH sensor ON always to 12V.
'Read Air Temperature Sensor; Single-End Measurement
VoltSe (AirTemp_C,1,mV2500,4,0,0,_60Hz,0.1,-40)
'Read Relative Humidity Sensor; Single-End Measurement
VoltSe (RH,1,mV2500,7,0,0,_60Hz,0.1,0)

```

'Correction for sensor inaccuracy when RH near 100%  
 If RH>100 AND RH<103 Then RH=100  
 'Calculate Dew Point from Measured Air Temperature and Relative Humidity  
 DewPoint (DewPoint\_C,AirTemp\_C,RH)

'''''''' Calculate Wind Chill ''''''''

'From page 180 of the 2006 Alaska Safety Handbook (BP Exploration (Alaska) Inc.,  
 ConocoPhillips Alaska)

'Wind Chill (°F) = 35.74 + 0.6215T - 35.75 (V^0.16 ) + 0.4275T(V^0.16 )

' Where, T=Air Temperature (°F) V=Wind Speed (mph)

'Air temperaute is measured every execution interval wind chill is computed every exection  
 interval with the current wind speed and previous

' the equation only applies if ws is >= 3 mph and air temp is <= 50 F then apply the equation,  
 other wise WindChill temp remains Air Temp.

AirTemp\_F = AirTemp\_C \* (9/5) + 32

WSpd\_mph = WSpd\_ms \* 2.2369363

' set wind chill temp to air temp

WindChill\_F = AirTemp\_F

WindChill\_F = 35.74 + 0.6215 \* AirTemp\_F - 35.75 \* (WSpd\_mph^0.16) + 0.4275 \*

AirTemp\_F \* (WSpd\_mph^0.16)

WindChill\_C = (WindChill\_F - 32) \* 5/9 'Added 05/08/08 RFP

If WSpd\_mph < 3 OR AirTemp\_F > 50 Then WindChill\_F = AirTemp\_F

If WSpd\_mph < 3 OR AirTemp\_F > 50 Then WindChill\_C = AirTemp\_C

'''''''' Read Solar Radiation - LI200X Pyranometer; Output units are W/m2  
 VoltDiff (SolRad\_W\_m2,1,mV7\_5,3,True ,0,\_60Hz,200,0)

'''''''''' Compute Saturated, Actual and Deficit Vapor Pressure

SatVP (VPsat\_kPa,AirTemp\_C)

VaporPressure (VPact\_kPa,AirTemp\_C,RH)

VPdef\_kPa = VPsat\_kPa - VPact\_kPa

\*\*\*\*\*

" READ AM16/32 #1 MULTIPLEXER Every 1 minute "

\*\*\*\*\*

PortSet (2,1 ) 'TURN ON AM16/32 #1 MULTIPLEXER, SET PORT 2 HIGH

i = 1 'INITIALIZE INDEX INTERGER I TO ONE

'READ 36 GWS THERMISTORS

SubScan (0,Sec,5) 'SCAN LOOP -- 5 ITERATIONS

PulsePort (3,10000) 'ADVANCE AM16/32 #1 GROUP BY 1, PULSE PORT 3

'MEASURE GWS THERMISTORS, (Voltage Ratio X = Rs/(Rs+Rf))

BrHalf (therm(i),1,mV2500,1,Vx1,1,2500,True ,0,\_60Hz,1.0,0)

```

i = i + 1
BrHalf (therm(i),1,mV2500,2,Vx1,1,2500,True ,0,_60Hz,1.0,0)
i = i + 1
BrHalf (therm(i),1,mV2500,3,Vx1,1,2500,True ,0,_60Hz,1.0,0)
i = i + 1
NextSubScan
PortSet (2,0)      'TURN OFF AM16/32 #1 MULTIPLEXER, SET PORT 2 LOW

'CONVERT MEASURED VOLTAGE RATIO TO RESISTANCE (kOHM) FOR 36 GWS
THERMISTORS
For i=1 To 15
  Therm_kOhm(i) = Rf*therm(i)/(1-therm(i))
Next i

'CONVERT GWS THERMISTOR RESISTANCE TO deg C FOR 36 GWS
THERMISTORS
For i=1 To 15
  D(i) = LN (1000*Therm_kOhm(i))           'ln resistance (ohm)
  Temp_C(i) = (1/(a + b*D(i) + c*(D(i))^3)) - 273.15  'Steinhart & Hart Equation
Next i

'''''''' CS100 barometric pressure sensor wired ON with a jumper on the sensor between
Supply and
'''''''' Read CS100 Barometric Pressure Sensor; Output in mb Uncorrected for elevation
" range 600 to 1100mb = 0 to 1 vdc; M = 0.2, 0 = 600mbar
VoltSe (BaroPrNC_mB,1,mV2500,16,1,0,_60Hz,0.2,600)

EndIf 'End of 60-second scan loop

CallTable HourlyDiag
CallTable Hourly
CallTable QuarterHrlyMet
CallTable TwoMinWd
CallTable QuarterHourlyWater
CallTable HourlyRaw
CallTable Daily
CallTable HrlyClimate
CallTable HourlySubs

If IfTime (0,1440,Min) Then
  DlyBatCrtIn_AHr = 0
  DlyBatCrtOut_AHr = 0
EndIf

NextScan
EndProg

```

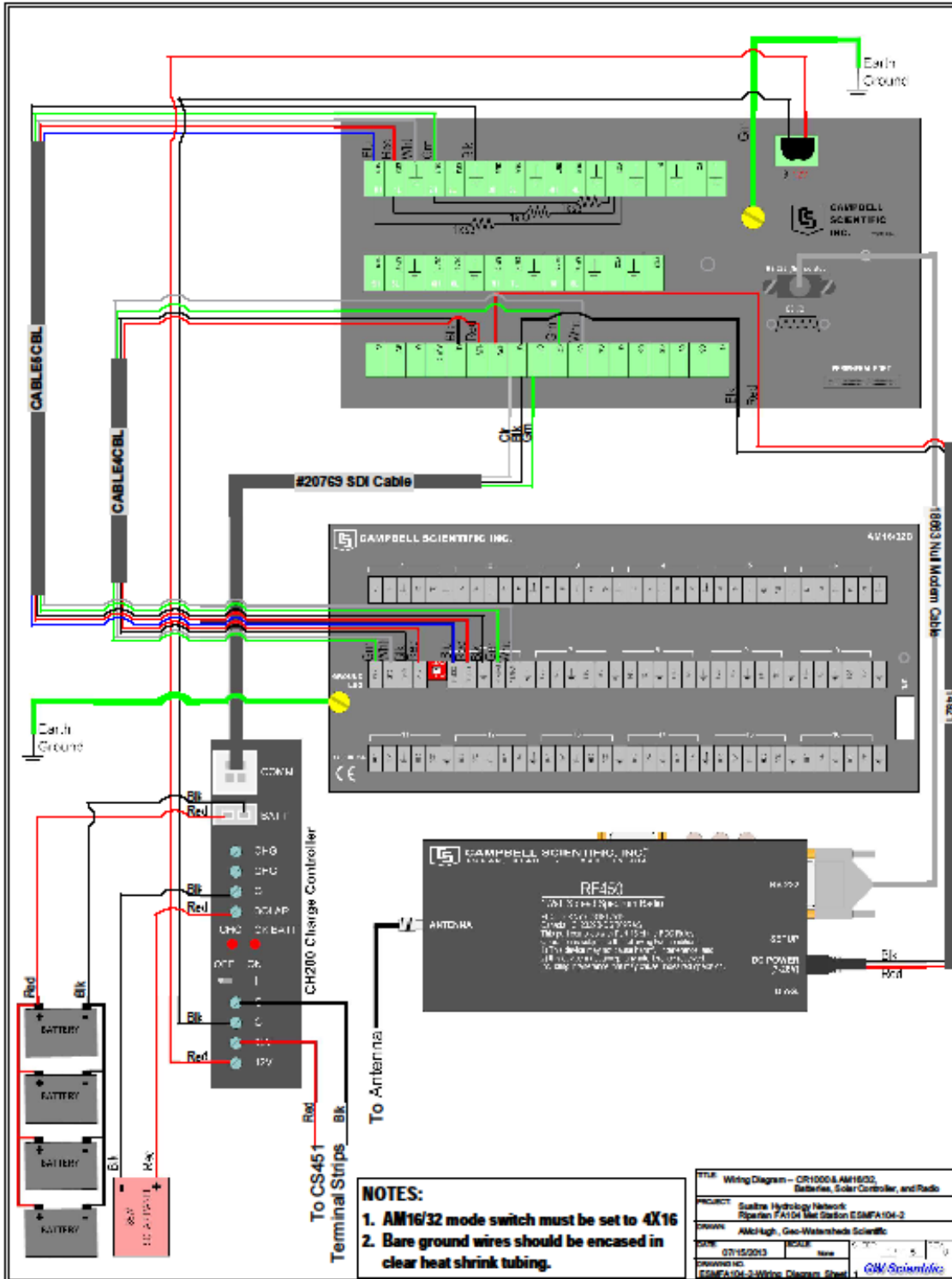


Figure C-6. ESMFA104-2 Sheet 1 (Data Logger, Power, Radio, Multiplexer).

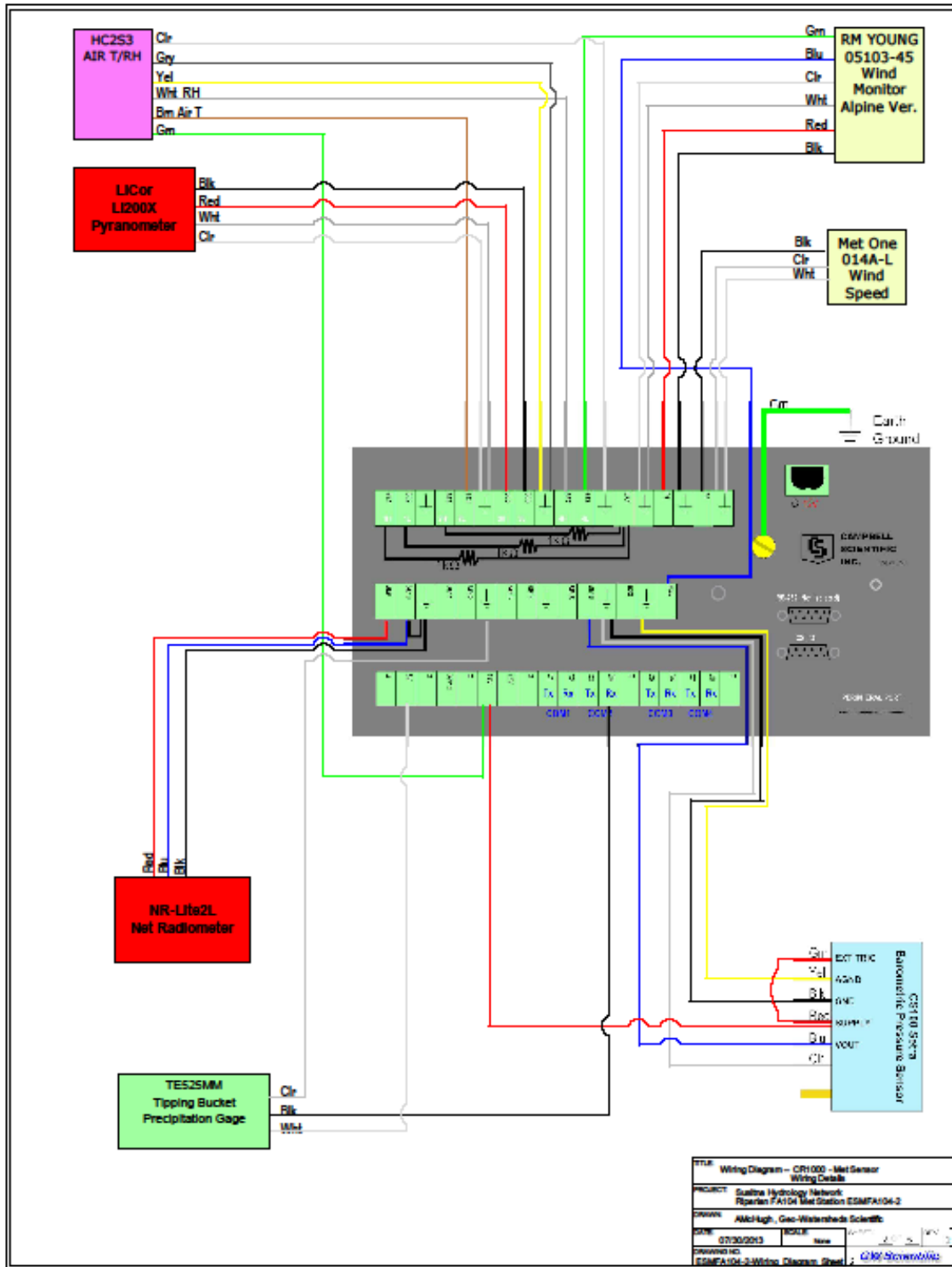


Figure C-7. ESMFA104-2 Sheet 2 (Data Logger, Met Sensors).

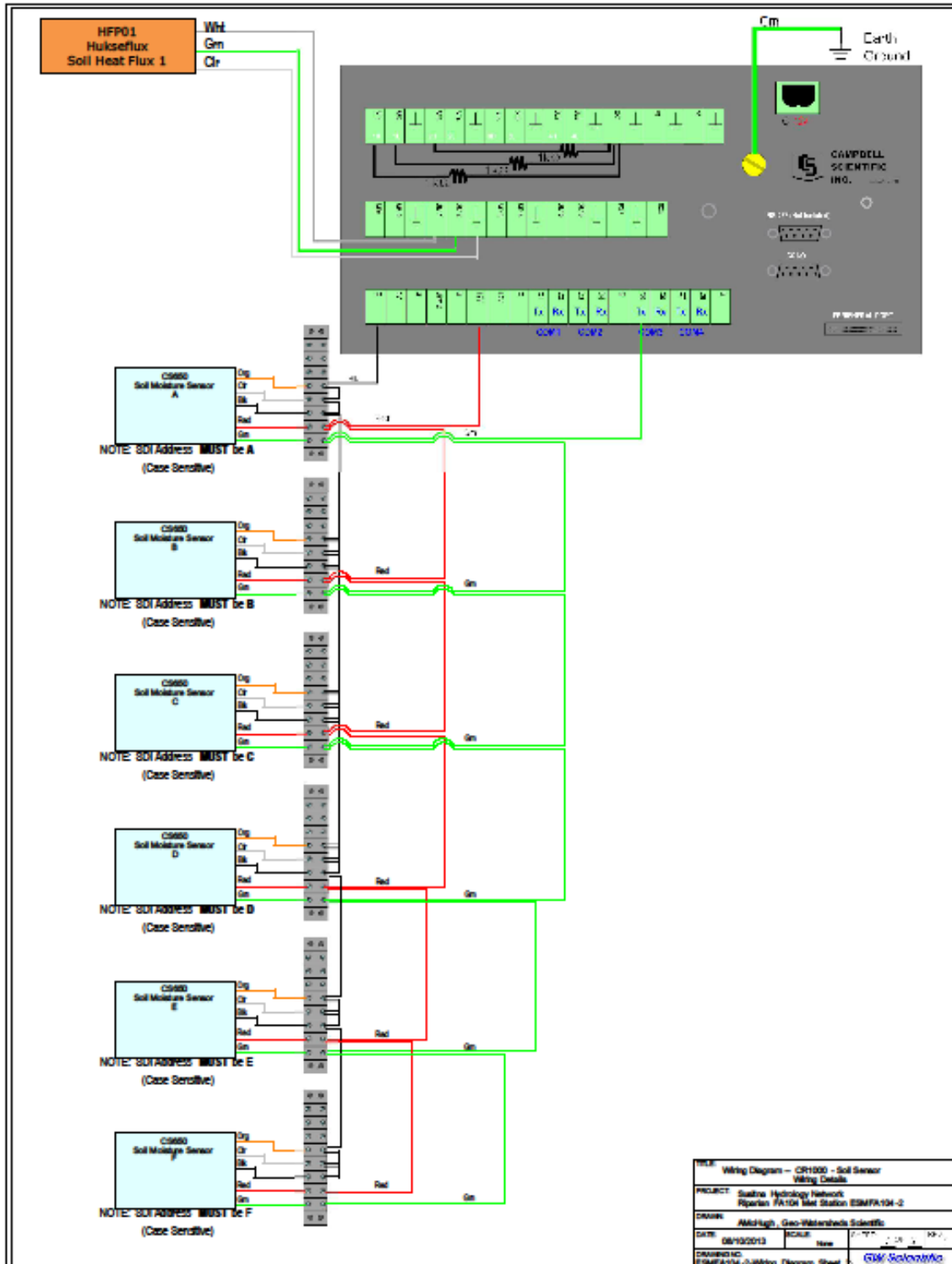


Figure C-8. ESMFA104-2 Sheet 3 (Soil Sensors).

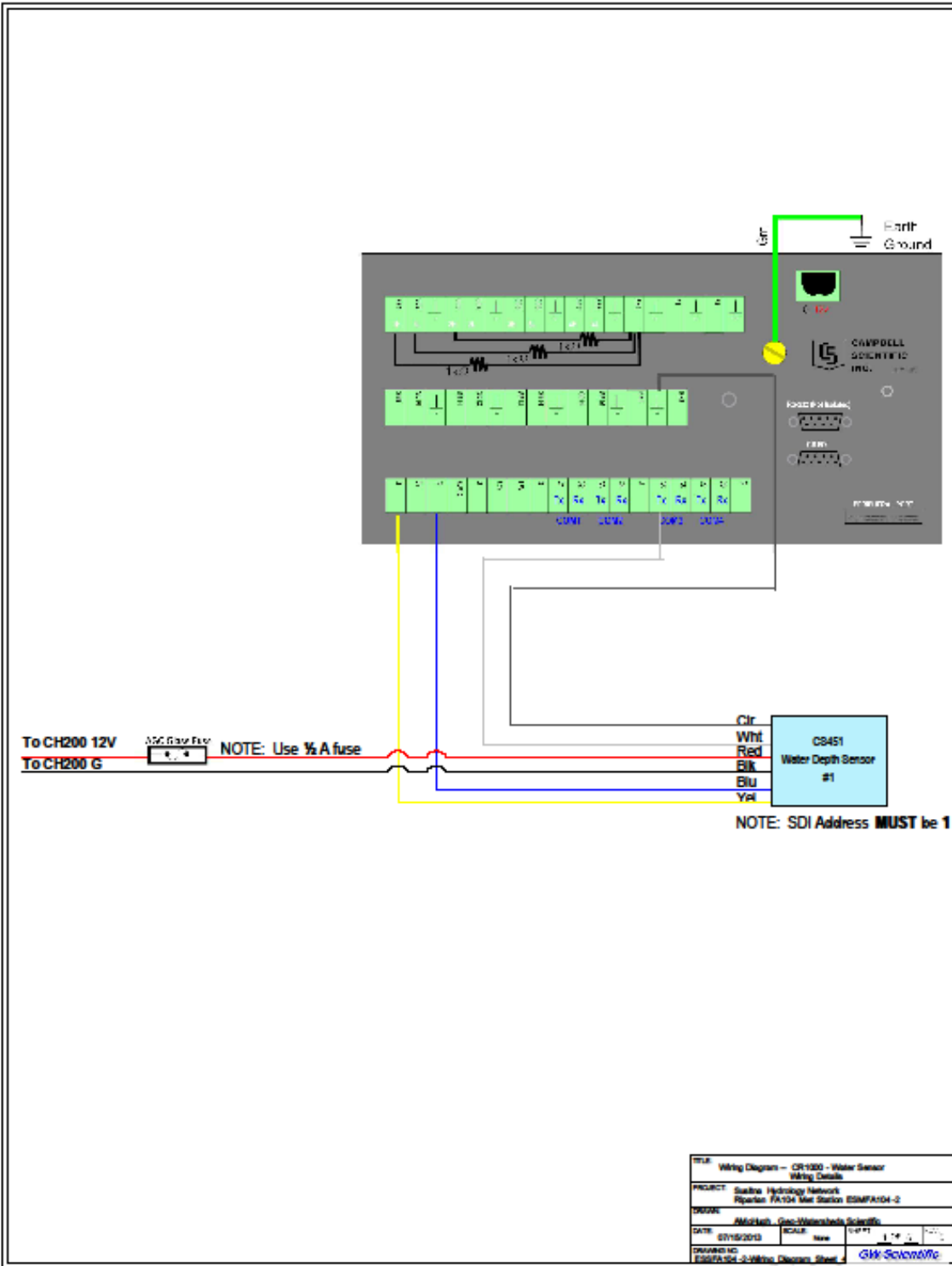


Figure C-9. ESMFA104-2 Sheet 4 (CS Water Sensors).





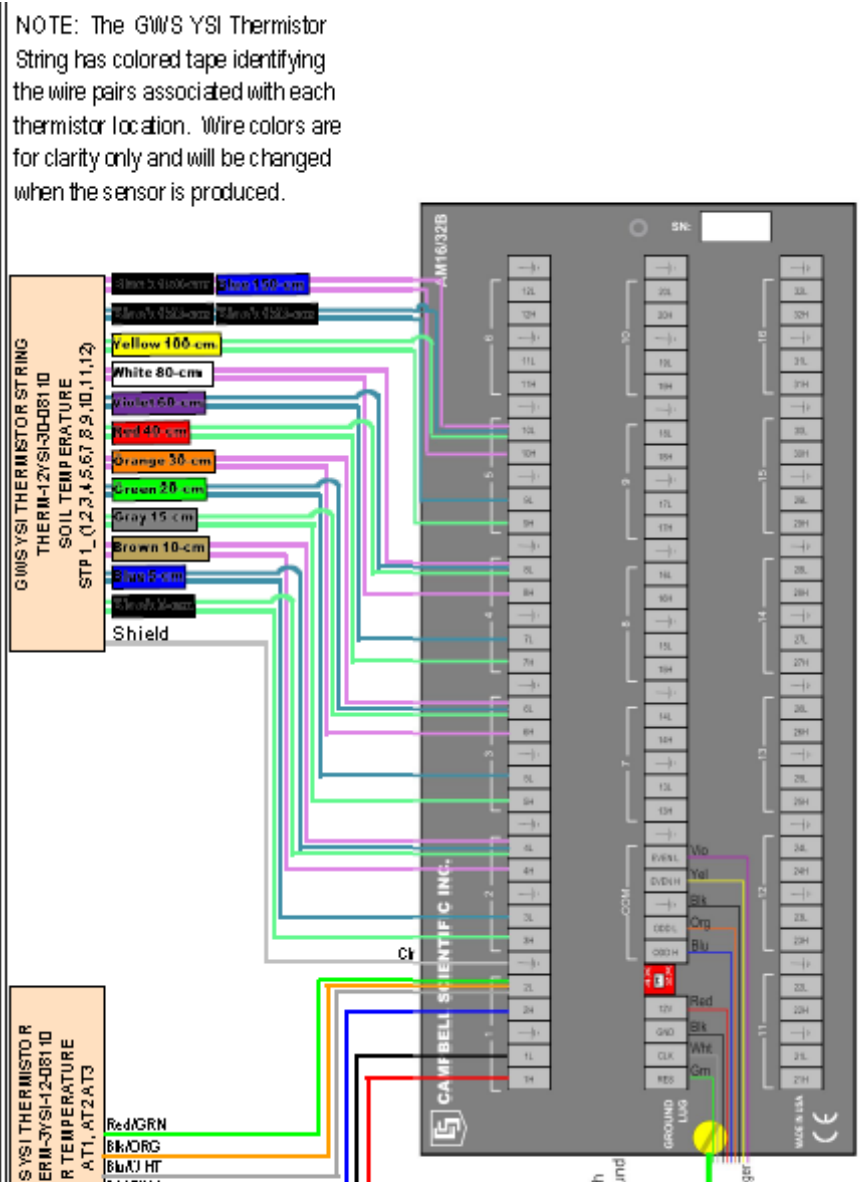


Figure C-11. ESMFA104-2 Sheet 5 (Multiplexer, Sensors).

**The following program and wiring diagrams depict FA-104 (Whiskers Slough) station ESMFA104-3, representative of the groundwater (CSI CR200X) type station:**

'CR200 Series Datalogger

'Modification Of:

'Modified by:

'Date Modified:

'Modifications:

' PakBus ID for Station: 395 'INSERT PakBus ID HERE <=====

' Station ID: 395 'INSERT Station ID HERE <=====

' Time is set to AK Standard Time

.....

"" INDIVIDUAL STATION INPUTS ""

.....

'INSERT Station ID HERE:

Const ID = 395 'INSERT Station ID HERE <=====

'CONTROL PORTS

' C1 SDI-12 Buss: CH200 - Charging Regulator; PTs

' C2

Public StationID ' Station ID number, USER INPUT

Public BattVolts\_V

Public DlyBatCrtIn\_AHr, DlyBatCrtOut\_AHr

Public LoadPwr\_W, ChargePwr\_W

Public CS450Data1(2) 'Water Level Sensor 1 - pressure, temperature

Public CS450Data2(2) 'Water Level Sensor 2 - pressure, temperature

Public CS450Data3(2) 'Water Level Sensor 3 - pressure, temperature

Public WaterHt1\_cm, WaterHt1\_ft, WaterHt2\_cm, WaterHt2\_ft, WaterHt3\_cm, WaterHt3\_ft

' Water level above the probe

Public CH200\_MX(4) ' Array to hold extended data from CH200

Alias CH200\_MX(1) = BattTargV ' Battery charging target voltage

Alias CH200\_MX(2) = DgtlPotSet ' Digital potentiometer setting

Alias CH200\_MX(3) = BattCap ' Present battery capacity

Alias CH200\_MX(4) = Qloss ' Battery charge deficit

Public CH200\_M0(9) 'Array to hold all data from CH200 charge controller

Alias CS450Data1(1) = WaterHt1\_psi

Alias CS450Data1(2) = WaterT1\_C

Alias CS450Data2(1) = WaterHt2\_psi

Alias CS450Data2(2) = WaterT2\_C

Alias CS450Data3(1) = WaterHt3\_psi

Alias CS450Data3(2) = WaterT3\_C

Alias CH200\_M0(1)=CH200BattVolts\_V 'Battery voltage: VDC

Alias CH200\_M0(2)=BattCrnt\_A 'Current going into, or out of, the battery: Amps

Alias CH200\_M0(3)=LoadCrnt\_A 'Current going to the load: Amps

Alias CH200\_M0(4)=SolarPanel\_V 'Voltage coming into the charger: VDC

Alias CH200\_M0(5)=SolarPanel\_A 'Current coming into the charger: Amps

Alias CH200\_M0(6)=Chgr\_Tmp\_C 'Charger temperature: Celsius

Alias CH200\_M0(7)=Chgr\_State 'Charging state: 2=Cycle, 3=Float, 1=Current Limited, or 0=None

Alias CH200\_M0(8)=Chgr\_Source 'Charging source: 0=None, 1=Solar, or 2=AC

Alias CH200\_M0(9)=Ck\_Batt 'Check battery error: 0=normal, 1=check battery

Dim Initialized

DataTable (QuarterHrWater,1,-1)

DataInterval (0,15,min)

Sample (1,StationID)

Sample (1,WaterHt1\_ft)

Average (1,WaterHt1\_ft,False)

Sample (1,WaterHt2\_ft)

Average (1,WaterHt2\_ft,False)

Sample (1,WaterHt3\_ft)

Average (1,WaterHt3\_ft,False)

Sample (1,WaterT1\_C)

Sample (1,WaterT2\_C)

Sample (1,WaterT3\_C)

Sample (1,WaterHt1\_psi)

Average (1,WaterHt1\_psi,False)

Sample (1,WaterHt2\_psi)

Average (1,WaterHt2\_psi,False)

Sample (1,WaterHt3\_psi)

Average (1,WaterHt3\_psi,False)

EndTable

'Hourly Diagnostics Table

DataTable (HourlyDiag,1,-1)

DataInterval (0,60,Min)

Sample (1,StationID)

'BATTERY VOLTS (V)

Sample (1,BattVolts\_V)

Average (1,BattVolts\_V,False)

'BATTERY CURRENT (A)

Sample (1,CH200\_M0(2))

Average (1,CH200\_M0(2),False)

'LOAD CURRENT (A)

Sample (1,CH200\_M0(3))

Average (1,CH200\_M0(3),False)

'SOLAR PANEL VOLTS (V)

Sample (1,CH200\_M0(4))

Average (1,CH200\_M0(4),False)

'SOLAR PANEL CURRENT (A)

Sample (1,CH200\_M0(5))

Average (1,CH200\_M0(5),False)

'Charge Regulator Temperature (deg C)

Average (1,CH200\_M0(6),False)

Sample (1,BattCap)

Average (1,ChargePwr\_W,False)

EndTable

'Hourly Climate Table (for Current Conditions Table on Web)

DataTable (HrlyClimate,1,96)

DataInterval (0,60,Min)

Sample (1,StationID)

Sample (1,WaterT1\_C)

Sample (1,WaterHt1\_ft)

Sample (1,WaterT2\_C)

Sample (1,WaterHt2\_ft)

Sample (1,WaterT3\_C)

Sample (1,WaterHt3\_ft)

EndTable

'Daily Output Table

DataTable (Daily,1,-1)

DataInterval(0,1440,Min)

Sample (1,StationID)

Maximum (1,WaterHt1\_ft,False,0)

Minimum (1,WaterHt1\_ft,False,0)

Maximum (1,WaterHt2\_ft,False,0)

Minimum (1,WaterHt2\_ft,False,0)

Maximum (1,WaterHt3\_ft,False,0)

Minimum (1,WaterHt3\_ft,False,0)

Maximum (1,WaterT1\_C,False,0)

Minimum (1,WaterT1\_C,False,0)

Maximum (1,WaterT2\_C,False,0)

Minimum (1,WaterT2\_C,False,0)

Maximum (1,WaterT3\_C,False,0)

Minimum (1,WaterT3\_C,False,0)

EndTable

'Main Program

BeginProg

Scan (60,Sec)

"" Set Station ID ""

StationID = ID

' Measure Battery Voltage (V)

Battery (BattVolts\_V)

'CH200 CHARGE REGULATOR MEASUREMENTS

' Connected to Control Port 1

' We will use the default address of 0.

SDI12Recorder (CH200\_M0(),"0M!",1.0,0)

'Get additional values from CH200

SDI12Recorder (CH200\_MX(),"M6!",1.0,0)

' Compute running Power and daily running total AmpHours/Day values for each current measurement.

LoadPwr\_W = CH200BattVolts\_V \* LoadCrnt\_A

ChargePwr\_W = SolarPanel\_V \*SolarPanel\_A

' Divide each 1 minute Amp sample by 1440 sample/day so that the total at the end of the day is to get avg current for the day

' then multiply by 24 Hr/day to get AHr/Day. or divide by 60 because 24/1440 = 1/60

' Separate and sum each the positive and negative currents into and out of the battery to get the total AHr in/out for the day.

' Sample hourly and daily, then zero at end of the day.

If BattCrnt\_A > 0 Then DlyBatCrntIn\_AHr = DlyBatCrntIn\_AHr + BattCrnt\_A/60

If BattCrnt\_A < 0 Then DlyBatCrntOut\_AHr = DlyBatCrntOut\_AHr + BattCrnt\_A/60

.....

" READ CSI SDI-12 CS450 water level/temp "

.....

' There are up to three CSI CS451 or INW PT12 SDI-12 vented water level pressure transducers.

' Each sensor is connected to Control Port 1

' Each sensor has a unique SDI-12 address 1,2 and 3.

```
SDI12Recorder (CS450Data1(),"1M!",1.0,0)
SDI12Recorder (CS450Data2(),"2M!",1.0,0)
SDI12Recorder (CS450Data3(),"3M!",1.0,0)
```

```
' convert water heights in psi to cm (70.307 cm/psi)
```

```
WaterHt1_cm = WaterHt1_psi * 70.307
```

```
WaterHt2_cm = WaterHt2_psi * 70.307
```

```
WaterHt3_cm = WaterHt3_psi * 70.307
```

```
'Convert Water Height in cm to ft. (0.0328 ft/cm)
```

```
WaterHt1_ft = WaterHt1_cm * 0.0328
```

```
WaterHt2_ft = WaterHt2_cm * 0.0328
```

```
WaterHt3_ft = WaterHt3_cm * 0.0328
```

```
CallTable QuarterHrWater
```

```
CallTable HourlyDiag
```

```
CallTable HrlyClimate
```

```
CallTable Daily
```

```
If IfTime (0,1440,Min) Then
```

```
  DlyBatCrtIn_AHr = 0
```

```
  DlyBatCrtOut_AHr = 0
```

```
EndIf
```

```
NextScan
```

```
EndProg
```



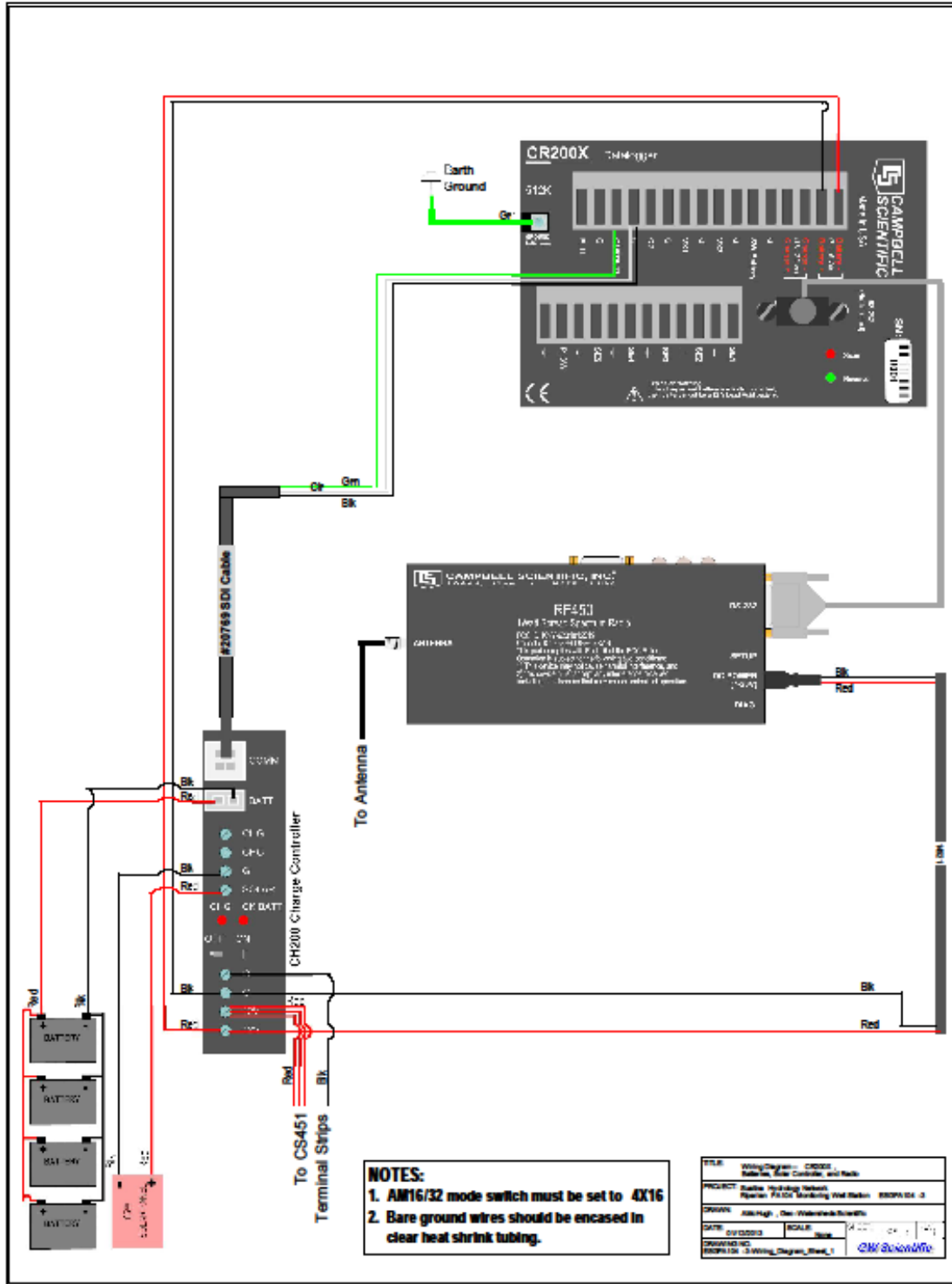


Figure C-12. ESFA104-3 Sheet 1 (Data Logger, Power, Radio).

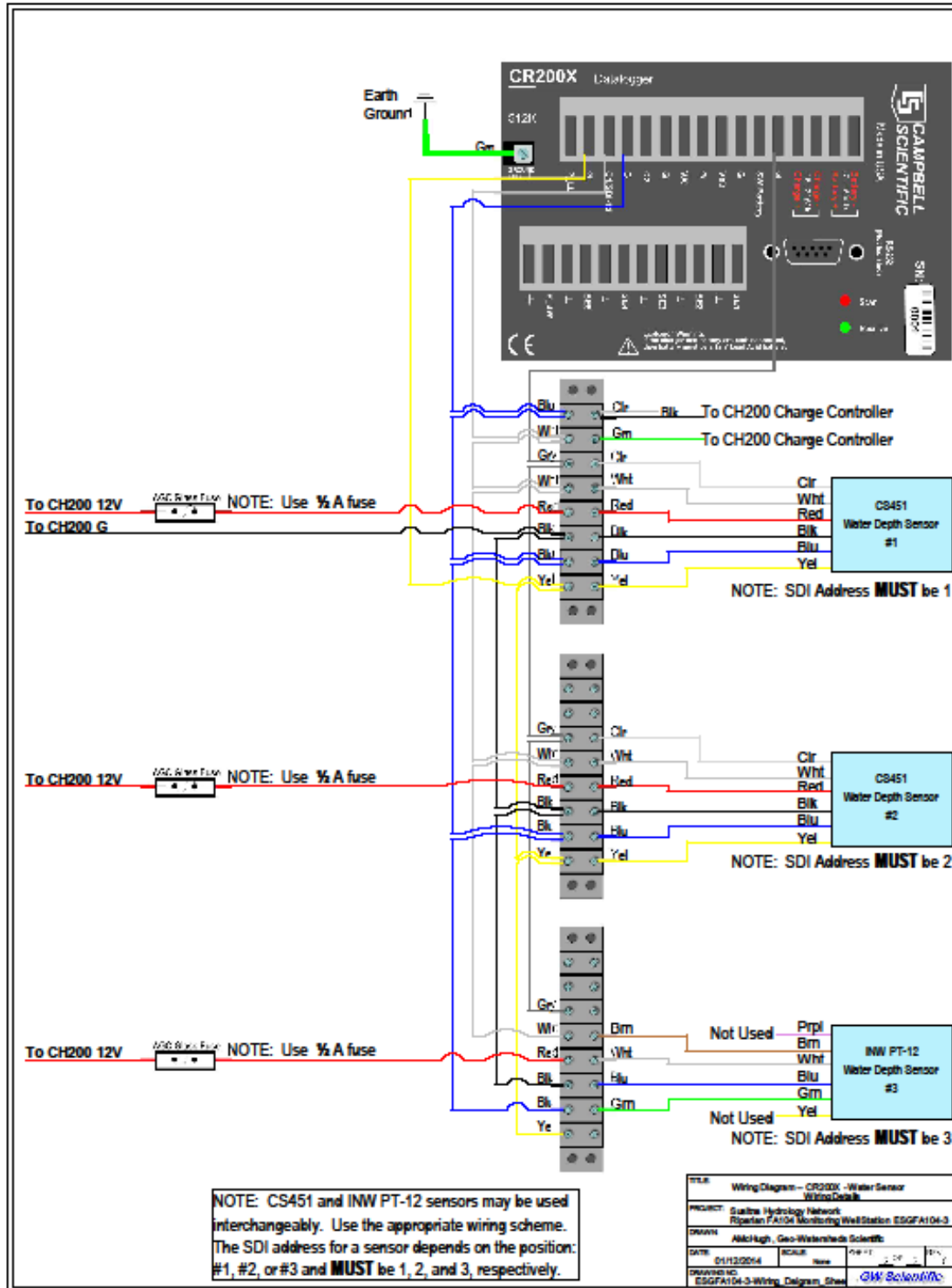


Figure C-13. ESGFA104-3 Sheet 2 Mix (Data Logger, INW/CSI Sensors).

**The following program and wiring diagrams depict FA-104 (Whiskers Slough) station ESGFA104-4, representative of the groundwater (CR1000, sap flow sensors) data type station:**

'CR1000 Series Datalogger

' Well Monitoring with Sap Flow

' Sensor count (22) TDP30s / (10) TDP50s

' Program Name ESGFA104-4\_20131108.cr1

'Modification Of: ESGFA104-4\_130725.cr1

'Modified By: R Paetzold

'Date Modified: 8Nov2013

'Modifications: Added Sap Flow Heater control commands to turn power ON/OFF

'       The heater is initially ON; To turn OFF, find SapHtrControlMode

'       and add to a Numeric Display, right click, select View/Modify Value and change ON to OFF.

'       To turn heater ON, find SapHtrControlMode & add to a Numeric Display, right click, select View/Modify Value and change OFF to ON.

'       Default mode is heater ON.

'Modification Of: ESGFA104-4.CR1

'Modified By: AMcHugh

'Date Modified: 16July2013

'Modifications: Added CH200 code

'Modification Of: 'FLGS-TDP.CR1                      Release Program Version 2.1

'Modified By: AMcHugh

'Date Modified: 30June2013

'Modifications: Added PT stuff from ESGFA115-5\_130627.cr1, changed to GWS Public

' variable names if needed.

'Dynamax Inc

'10808 Fallstone Rd, Ste 350, Houston, TX 77099

'Phone: 281-564-5100

'Fax: 281-564-5200

'www.Dynamax.com

'Program: FLGS - TDP using CR1000

'Program author: Sai Gonuguntla, Dynamax, Inc

'////////////////////// CONSTANTS ////////////////////////

'INSERT Station Name HERE:

StationName (ESGFA104-4) 'INSERT Station Name HERE

<=====

'INSERT Station ID HERE:

Const ID = 396 'INSERT Station ID HERE

<=====

'////////////////////////////////////

' BEGIN: User constants

' User can change the following constants only

'////////////////////////////////////

Const INT\_SCAN = 60 ' Scan every seconds

Const INT\_AVG = 60 ' Average every minutes average and LOG interval are same

Const NUM\_TDP = 32 ' Number of TDP sensors

Const NUM\_TC = 32 ' Number of Thermocouples/ measurement points among all the TDP sensors

' A TDP10/30/50 each has 1, a TDP80 sensor has 2 & a TDP100 sensor has 3 thermocouples/ measurement points

' So total number of Thermocouples(NUM\_TC) must be determined depending on the number and type of sensors in use

' For example a system with 4 TDP30 sensors and 2 TDP80 sensors and 2 TDP100 sensors

' will have in all 14 thermocouples/ measurement points ' i.e. NUM\_TC = 14

Const DTMIN = 0.2 ' Minimum differential below which the measurement from sensor is ignored

Const WARMUP\_MIN = 60 ' Warmup time in min before the measurements are considered valid

Const FIELDINDEX = 1.0 ' This is the index value either Area INdex/ LAI used to scale plant sapflow to field

Const FLAG\_INDEX\_EN=0 ' Enable scaling of sapflow to the field

Const FLAG\_VOTE\_EN=0 ' Enable voting algorithm

Const PS\_ENABLE = 0 ' Enable power save at night ' Note power save is not performed on a day when auto zero is done

Const PS\_START=1260 ' Power save start (Heater off) min-since mid night

' time at which to start the power save, 1260 corresponds to 21:00 hours or 9:00 PM

Const PS\_STOP=300 ' Power save end (Heater on) hour-since mid night

' time at which to stop power save mode and turn heaters ON, 300 corresponds to 5AM

Const ZERO\_ENABLE=1 ' Enable auto calibration/ auto sero

Const ZERO\_STARTHOUR=1 ' Top of the Hour at which to start auto zero algorithm, must 1:00 am or more

Const ZERO\_STOPHOUR=3 ' Top of the Hour at which to stop performing auto zero and compute new zero (dTM) value.

Const ZERO\_DAYINT=1 ' Number of days between successive auto-zero

```
'////////////////////
'      END User modified constants
'////////////////////
```

```
Const TIMER_START=0      '      0      Start
Const TIMER_STOP=1      '      1      Stop
Const TIMER_RSTnSTART=2  '      2      Reset and start
Const TIMER_STOPnRST=3  '      3      Stop and reset
Const TIMER_READONLY=4  '      4      Read only
```

```
' FLGS TC-Status
Const TCSTAT_OFF      =      0
Const TCSTAT_OKV      =      1
Const TCSTAT_OKN      =      2      ' This status is not applicable but
used for consistency with numbers
Const TCSTAT_WARM     =      3
Const TCSTAT_FAULT    =      4
Const TCSTAT_MERR     =      5
Const TCSTAT_ZERO     =      6
Const TCSTAT_MAX      =      7
Const TCSTAT_REV      =      8
```

```
' FLGS TDP-Status
Const TDPSTAT_OFF     =      0
Const TDPSTAT_OKV     =      1
Const TDPSTAT_OKN     =      2
Const TDPSTAT_WARM    =      3
Const TDPSTAT_FAULT   =      4
Const TDPSTAT_MERR    =      5
Const TDPSTAT_ZERO    =      6
Const TDPSTAT_MAX     =      7
Const TDPSTAT_NALL    =      8
Const TDPSTAT_ERRCH   =      9
```

```
'IDs for sensor 5and sensor TCs
Const TDP10 = 10.0
Const TDP30 = 30.0
Const TDP50 = 50.0
Const TDP80 = 80.0
Const TDP80A = 80.0
Const TDP80B = 80.1
Const TDP100= 100.0
Const TDP100A = 100.0
Const TDP100B = 100.1
```

Const TDP100C = 100.2

'Declare Variables and Units

' System constants

Const MAX\_TDP = 32 ' maximum num of thermocouple channels

Const MAX\_TC = 32 ' maximum num of thermocouple channels

' Heater constants

Const TIMERNO\_WARMUP=1

Const NUM\_HTR=4 'Number of heater voltages

Const HTROFF\_VOLT=0.5 'Heater voltage less than this  
is OFF

' Calculation constants

Const MV\_TO\_DT\_MULT=25.0 'Multiplier mV to dT conversion

Const MV\_TO\_DT\_OFFSET=0.0 'Offset mV to dT conversion

' Public Variables

PreserveVariables ' variables are maintained over reboot.

Public StationID ' Station ID number, USER INPUT

Public BattVolts\_V

Public LoggerTemp\_C

Public SapHtrControlMode As String \* 2 'ON' or 'OFF'

Public SapHtrControlStatus

Public DlyBatCrtIn\_AHr, DlyBatCrtOut\_AHr

Public LoadPwr\_W, ChargePwr\_W

Public CH200\_M0(9) 'Array to hold all data from CH200

Public CH200\_MX(4) ' Array to hold extended data from CH200

Alias CH200\_MX(1) = BattTargV ' Battery charging target voltage

Alias CH200\_MX(2) = DgtlPotSet ' Digital potentiometer setting

Alias CH200\_MX(3) = BattCap ' Present battery capacity

Alias CH200\_MX(4) = Qloss ' Battery charge deficit

' SDI-12 formatted battery capacity value

Public SDI12command As String

' Response from CH200. Retrns the address of the unit and "ok" if all went well

Public SDI12result As String

Public NEWBATTCAP ' the new battery capacity if you need to change it.

Public PT1Data(2) 'Water Level Sensor 1 - pressure, temperature

Public WaterHt1\_cm, WaterHt1\_ft ' Water level above the probe

Alias PT1Data(1) = WaterHt1\_psi

Alias PT1Data(2) = WaterT1\_C

Alias CH200\_M0(1)=CH200BattVolts\_V 'Battery voltage: VDC  
 Alias CH200\_M0(2)=BattCrnt\_A 'Current going into, or out of, the battery: Amps  
 Alias CH200\_M0(3)=LoadCrnt\_A 'Current going to the load: Amps  
 Alias CH200\_M0(4)=SolarPanel\_V 'Voltage coming into the charger: VDC  
 Alias CH200\_M0(5)=SolarPanel\_A 'Current coming into the charger: Amps  
 Alias CH200\_M0(6)=Chgr\_Tmp\_C 'Charger temperature: Celsius  
 Alias CH200\_M0(7)=Chgr\_State 'Charging state: 2=Cycle, 3=Float, 1=Current Limited, or  
 0=None  
 Alias CH200\_M0(8)=Chgr\_Source 'Charging source: 0=None, 1=Solar, or 2=AC  
 Alias CH200\_M0(9)=Ck\_Batt

'////////////////////////////////////

Public InputTDP001 As String \* 200  
 Public InputTDP002 As String \* 200  
 Public InputTDP003 As String \* 200  
 Public InputTDP004 As String \* 200  
 Public InputTDP005 As String \* 200  
 Public InputTDP006 As String \* 200  
 Public InputTDP007 As String \* 200  
 Public InputTDP008 As String \* 200  
 Public InputTDP009 As String \* 200  
 Public InputTDP010 As String \* 200  
 Public InputTDP011 As String \* 200  
 Public InputTDP012 As String \* 200  
 Public InputTDP013 As String \* 200  
 Public InputTDP014 As String \* 200  
 Public InputTDP015 As String \* 200  
 Public InputTDP016 As String \* 200  
 Public InputTDP017 As String \* 200  
 Public InputTDP018 As String \* 200  
 Public InputTDP019 As String \* 200  
 Public InputTDP020 As String \* 200  
 Public InputTDP021 As String \* 200  
 Public InputTDP022 As String \* 200  
 Public InputTDP023 As String \* 200  
 Public InputTDP024 As String \* 200  
 Public InputTDP025 As String \* 200  
 Public InputTDP026 As String \* 200  
 Public InputTDP027 As String \* 200  
 Public InputTDP028 As String \* 200  
 Public InputTDP029 As String \* 200  
 Public InputTDP030 As String \* 200  
 Public InputTDP031 As String \* 200  
 Public InputTDP032 As String \* 200

Public readstring As String \* 200

Public ArrayTemp(10)

////////////////////////////////////

Public RealTimeArray(9)

Public RealTimeSec

Public RealTimeMin

Public RealTimeHour

Public Count\_Day

Public JDAY

Public JHM

Public HtrV(4)

Public Htr\_ON\_Time

Public Flag\_HtrOff

'New set of variables

Public iTC ', NUM\_TC

Public TC\_Sno(32)

Public TC\_Stype(32)

Public TC\_dTC(32)

Public TC\_dTCa(32)

Public TC\_dTM(32)

Public TC\_SArea(32)

Public TC\_Flow(32)

Public TC\_Vel(32)

' Velocity in cm/h , MVB- 11-18-08

Public TC\_Status(32)

Public iTDP 'NUM\_TDP,

Public TDP\_SType(32)

Public TDP\_nCH(32)

Public TDP\_IArea(32)

Public TDP\_Flow(32)

Public TDP\_Status(32)

Public TDP\_FlowIx(32)

Public Flow\_AvgIx

Public Count\_OKV

Public nVoteout

Public Count\_OKN

Public MaxDiff(32)

Public MaxDiffAll

Public Flow\_Int

Public Hr\_Flow

Public DY\_Flow





'LOAD CURRENT (A)

Sample (1,CH200\_M0(3),FP2)

Average (1,CH200\_M0(3),FP2,False)

Maximum (1,CH200\_M0(3),FP2,False,False)

Minimum (1,CH200\_M0(3),FP2,False,False)

'SOLAR PANEL VOLTS (V)

Sample (1,CH200\_M0(4),FP2)

Average (1,CH200\_M0(4),FP2,False)

Maximum (1,CH200\_M0(4),FP2,False,False)

Minimum (1,CH200\_M0(4),FP2,False,False)

'SOLAR PANEL CURRENT (A)

Sample (1,CH200\_M0(5),FP2)

Average (1,CH200\_M0(5),FP2,False)

Maximum (1,CH200\_M0(5),FP2,False,False)

Minimum (1,CH200\_M0(5),FP2,False,False)

Average (1,LoggerTemp\_C,FP2,False) 'Logger Temperature (deg C)

Average (1,CH200\_M0(6),FP2,False) 'Charge Regulator Temperature (deg C)

Sample (1,NEWBATTCAP,FP2)

Sample (1,BattCap,FP2)

Sample (1,DlyBatCrtIn\_AHr,FP2)

Sample (1,DlyBatCrtOut\_AHr,FP2)

Average (1,ChargePwr\_W,FP2,False)

Maximum (1,ChargePwr\_W,FP2,False,False)

Minimum (1,ChargePwr\_W,FP2,False,False)

Average (1,LoadPwr\_W,FP2,False)

Maximum (1,LoadPwr\_W,FP2,False,False)

Minimum (1,LoadPwr\_W,FP2,False,False)

'Charger state

Sample (1,CH200\_M0(7),FP2)

EndTable

'15-minute Water Ttable

DataTable (QuarterHourlyWater,1,-1)

DataInterval(0,15,Min,0)

Sample (1,StationID,fp2)

Sample (1,WaterHt1\_cm,FP2)

Average (1,WaterHt1\_cm,FP2,False)

Maximum (1,WaterHt1\_cm,FP2,False,False)  
 Minimum (1,WaterHt1\_cm,FP2,False,False)

Sample (1,WaterHt1\_ft,FP2)  
 Average (1,WaterHt1\_ft,FP2,False)  
 Maximum (1,WaterHt1\_ft,FP2,False,False)  
 Minimum (1,WaterHt1\_ft,FP2,False,False)

Sample (1,WaterT1\_C,FP2)  
 Average (1,WaterT1\_C,FP2,False)  
 Maximum (1,WaterT1\_C,FP2,False,False)  
 Minimum (1,WaterT1\_C,FP2,False,False)

Sample (1,WaterHt1\_psi,FP2)  
 Average (1,WaterHt1\_psi,FP2,False)  
 Maximum (1,WaterHt1\_psi,FP2,False,False)  
 Minimum (1,WaterHt1\_psi,FP2,False,False)  
 EndTable

'Daily Output Table

DataTable (Daily,1,-1)  
 DataInterval(0,1440,Min,0)  
 Sample (1,StationID,fp2)

Average (1,WaterHt1\_cm,FP2,False)  
 Maximum (1,WaterHt1\_cm,FP2,False,False)  
 Minimum (1,WaterHt1\_cm,FP2,False,False)

Average (1,WaterHt1\_ft,FP2,False)  
 Maximum (1,WaterHt1\_ft,FP2,False,False)  
 Minimum (1,WaterHt1\_ft,FP2,False,False)

Average (1,WaterT1\_C,FP2,False)  
 Maximum (1,WaterT1\_C,FP2,False,False)  
 Minimum (1,WaterT1\_C,FP2,False,False)

Average (1,WaterHt1\_psi,FP2,False)  
 Maximum (1,WaterHt1\_psi,FP2,False,False)  
 Minimum (1,WaterHt1\_psi,FP2,False,False)  
 EndTable

'Hourly Climate Table (for Current Conditions Table on Web)

' Size limited to 96 data values or 4 days worth.

DataTable (HrlyClimate,1,96)  
 DataInterval (0,60,Min,0)  
 Sample (1,StationID,fp2)

Sample (1,WaterHt1\_cm,FP2)  
Sample (1,WaterHt1\_ft,FP2)  
Sample (1,WaterT1\_C,FP2)  
Sample (1,WaterHt1\_psi,FP2)  
EndTable

' Hourly Raw Table

DataTable (DailyRaw,1,-1)  
DataInterval(0,1440,Min,0)  
Sample (1,StationID,fp2)

Sample (1,InputTDP001,String) ' Sample TDP sensor settings strings  
Sample (1,InputTDP002,String)  
Sample (1,InputTDP003,String)  
Sample (1,InputTDP004,String)  
Sample (1,InputTDP005,String)  
Sample (1,InputTDP006,String)  
Sample (1,InputTDP007,String)  
Sample (1,InputTDP008,String)  
Sample (1,InputTDP009,String)  
Sample (1,InputTDP010,String)  
Sample (1,InputTDP011,String)  
Sample (1,InputTDP012,String)  
Sample (1,InputTDP013,String)  
Sample (1,InputTDP014,String)  
Sample (1,InputTDP015,String)  
Sample (1,InputTDP016,String)  
Sample (1,InputTDP017,String)  
Sample (1,InputTDP018,String)  
Sample (1,InputTDP019,String)  
Sample (1,InputTDP020,String)  
Sample (1,InputTDP021,String)  
Sample (1,InputTDP022,String)  
Sample (1,InputTDP023,String)  
Sample (1,InputTDP024,String)  
Sample (1,InputTDP025,String)  
Sample (1,InputTDP026,String)  
Sample (1,InputTDP027,String)  
Sample (1,InputTDP028,String)  
Sample (1,InputTDP029,String)  
Sample (1,InputTDP030,String)  
Sample (1,InputTDP031,String)  
Sample (1,InputTDP032,String)  
EndTable

'Intermediate table for dTC/ Internal table for calculating average of dTC only

```
DataTable(TableDT, True, 1)
  DataInterval(0,INT_AVG,Min,10)
  Average(NUM_TC,TC_dTC(),FP2,False)
EndTable
```

' Main table for TC(thermocouple) variables

```
DataTable(TableTC, True, -1)
  DataInterval(0,INT_AVG,Min,10)

  Sample (1,JDAY,FP2)
  Sample (1,JHM,FP2)
  Sample (NUM_TC,TC_dTCa(1),FP2)
  Sample (NUM_TC,TC_dTM(1),FP2)
  Sample (NUM_TC,TC_Vel(1),FP2)
  Sample (NUM_TC,TC_Flow(1),FP2)
  Sample (NUM_TC,TC_Status(1),FP2)
  Average(4,HtrV(),FP2,False)
  ,
```

```
  Minimum(1,BattVolts_V,FP2,False,0)
  Maximum(1,LoggerTemp_C,FP2,False,0)
  Sample (1,SapHtrControlMode,String)
  Sample (1,SapHtrControlStatus,FP2)
EndTable
```

'Table of SF calculations on each sensor along with indexed values and status codes

```
DataTable(TableTDP, True, -1)
  DataInterval(0,INT_AVG,Min,10)
  ,

  Sample (1,JDAY,FP2)
  Sample (1,JHM,FP2)
  Sample (NUM_TDP,TDP_Flow(1),FP2)
  Sample (NUM_TDP,TDP_FlowIx(1),FP2)
  Sample (NUM_TDP,TDP_Status(1),FP2)
EndTable
```

' Hourly Table

```
DataTable(TableHR, True, -1)
  DataInterval(0,60,Min,10)

  Sample (1,JDAY,FP2)
  Sample (1,JHM,FP2)
  Sample (1,Hr_Flow,FP2)
EndTable
```

' Daily Table

```
DataTable(TableDY, True, -1)
  DataInterval(0,1440,Min,10)
```

```
  Sample (1,JDAY,FP2)
  Sample (1,DY_Flow,FP2)
  Sample (NUM_TC,TC_dTM(1),FP2)
EndTable
```

' Test Table to test the autozero rundata and algorithm \*\* Removed 11-18-08

```
'DataTable(TableZRu,True,-1)
  DataInterval(0,INT_AVG,Min,10)

  Sample (1,JDAY,FP2)
  Sample (1,JHM,FP2)
  Sample (1,ZRun_Count,FP2)
  Sample (NUM_TC,ZRun_dT0(1),FP2)
  Sample (NUM_TC,ZRun_dT1(1),FP2)
  Sample (NUM_TC,ZRun_dT2(1),FP2)
  Sample (NUM_TC,ZRun_dTAvg(1),FP2)
  Sample (NUM_TC,ZRun_dTMax(1),FP2)

  Average(4,HtrV(),FP2,False)
  Minimum(1,BattVolts_V,FP2,False,0)
  Maximum(1,LoggerTemp_C,FP2,False,0)
'EndTable
```

' Test Table to test the autozero rundata and algorithm \*\* Removed 11-18-08

```
'DataTable(TableZDa,True,-1)
  DataInterval(0,INT_AVG,Min,10)

  Sample (1,JDAY,FP2)
  Sample (1,JHM,FP2)
  Sample (1,ZDay_Count,FP2)
  Sample (NUM_TC,ZDay_dT0(1),FP2)
  Sample (NUM_TC,ZDay_dT1(1),FP2)
  Sample (NUM_TC,ZDay_dT2(1),FP2)
  Sample (NUM_TC,ZDay_dTAvg(1),FP2)
  Sample (NUM_TC,ZDay_dTDiff(1),FP2)
  Sample (NUM_TC,ZDay_dTNew(1),FP2)

  Average(4,HtrV(),FP2,False)
  Minimum(1,BattVolts_V,FP2,False,0)
  Maximum(1,LoggerTemp_C,FP2,False,0)
'EndTable
```

////////////////////////////////// END TABLE DECLARATIONS//////////////////////////////////

//////////////////////////////////Begin Subroutines//////////////////////////////////

' Function for: Vote out one sensor

Sub VoteOut1

Count\_OKV=0

Flow\_AvgIx=0

For iTDP = 1 To NUM\_TDP Step 1

  If (TDP\_Status(iTDP)=TDPSTAT\_OKV) Then

    Flow\_AvgIx=Flow\_AvgIx+TDP\_FlowIx(iTDP)

    Count\_OKV=Count\_OKV+1

  EndIf

Next iTDP

Flow\_AvgIx = Flow\_AvgIx/Count\_OKV

For iTDP = 1 To NUM\_TDP Step 1

  If (TDP\_Status(iTDP) = TDPSTAT\_OKV) Then

    MaxDiff(iTDP) = ABS (TDP\_FlowIx(iTDP)-Flow\_AvgIx)

  EndIf

Next iTDP

MaxDiffAll = 0

For iTDP = 1 To NUM\_TDP Step 1

  If (MaxDiff(iTDP) > MaxDiffAll AND TDP\_Status(iTDP) = TDPSTAT\_OKV) Then

    MaxDiffAll=MaxDiff(iTDP)

    nVoteout=iTDP

  EndIf

Next iTDP

TDP\_Status(nVoteout)=TDPSTAT\_OKN

Count\_OKN=Count\_OKN+1

EndSub

' Function for: Running average of dT values

Sub AutoZeroRun

' All conditions for autozero are successful so perform running average

ZRun\_Count = ZRun\_Count + 1

For iTC = 1 To 32 Step 1

  If (ZRun\_Count = 0) Then

    'do nothing ' the control will never come here

  ElseIf (ZRun\_Count = 1) Then

    ZRun\_dT0(iTC) = TC\_dTCa(iTC)

    ZRun\_dTMax(iTC) = ZRun\_dT0(iTC)

'Added 4-20-08 MVB , Make sure

dTMax Initialized

```

ElseIf (ZRun_Count = 2) Then
  ZRun_dT1(iTC) = ZRun_dT0(iTC)
  ZRun_dT0(iTC) = TC_dTCa(iTC)

  If (ZRun_dT1(iTC) > ZRun_dT0(iTC)) Then      'Added 4-20-08 MVB
    ZRun_dTMax(iTC) = (ZRun_dT1(iTC)+ZRun_dT0(iTC))/2 ' In case only 2 readings taken
  Else
    ZRun_dTMax(iTC) = ZRun_dT0(iTC)
  EndIf
Else ' for all >=3
  ZRun_dT2(iTC) = ZRun_dT1(iTC)
  ZRun_dT1(iTC) = ZRun_dT0(iTC)
  ZRun_dT0(iTC) = TC_dTCa(iTC)

  ZRun_dTAvg(iTC) = (ZRun_dT2(iTC) + ZRun_dT1(iTC) + ZRun_dT0(iTC))/3

  'If (ZRun_Count = 3)
  'ZRun_dTMax(iTC) = ZRun_dTAvg(iTC)
  If (ZRun_dTAvg(iTC) > ZRun_dTMax(iTC))
    ZRun_dTMax(iTC) = ZRun_dTAvg(iTC)
    ' No Else here, using the previous dTmax
  EndIf
EndIf
Next i
EndSub

'Function for: Perform autozero day
Sub AutoZeroDay
  ' All conditions for autozero are successful so perform running average
  ZDay_Count = ZDay_Count + 1

  For iTC = 1 To 32 Step 1

    If (ZDay_Count <= 0) Then
      'do nothing ' the control will never come here

    ElseIf (ZDay_Count = 1) Then
      ZDay_dT2(iTC) = 0
      ZDay_dT1(iTC) = TC_dTM(iTC)
      ZDay_dT0(iTC) = ZRun_dTMax(iTC)

      ZDay_dTAvg(iTC) = (ZDay_dT1(iTC) + ZDay_dT0(iTC))/2
      ZDay_dTDiff(iTC) = ABS((ZDay_dT0(iTC) - ZDay_dTAvg(iTC)) *
100/ZDay_dTAvg(iTC))

      If ZDay_dTDiff(iTC) >= 10 Then

```



```

    ZDay_dTNew(iTC) = ZDay_dTAvg(iTC)
Else
    ZDay_dTNew(iTC) = ZDay_dT0(iTC)
EndIf
'dTM value is changed after the calibration or autozero during current day
TC_dTM(iTC) = ZDay_dTNew(iTC)

ElseIf (ZDay_Count >= 2) Then
    ZDay_dT2(iTC) = ZDay_dT1(iTC)
    ZDay_dT1(iTC) = ZDay_dT0(iTC)
    ZDay_dT0(iTC) = ZRun_dTMax(iTC)

    ZDay_dTAvg(iTC)      = (ZDay_dT1(iTC) + ZDay_dT1(iTC) + ZDay_dT0(iTC))/3
    ZDay_dTDiff(iTC) = ABS((ZDay_dT0(iTC) - ZDay_dTAvg(iTC)) *
100/ZDay_dTAvg(iTC))

    If ZDay_dTDiff(iTC) >= 10 Then
        ZDay_dTNew(iTC) = ZDay_dTAvg(iTC)
    Else
        ZDay_dTNew(iTC) = ZDay_dT0(iTC)
    EndIf
    'dTM value is changed after the calibration or autozero during current day
    TC_dTM(iTC) = ZDay_dTNew(iTC)
EndIf
Next iTC
EndSub
'//////////End Subroutines//////////

'Main Program
BeginProg
' Syntax for TDP sensors
'   InputTDP# = "TDP Type, Index Area, dTM1, SA1, dTM2, SA2, dTM3, SA3"
' Default all sensors are TDP30 with DTM=8.0 degC, SA = 1.0 sq.cm, and index area = 1.0
InputTDP001 = "30.0,1.00,9.50,1.00,8.00,1.00,8.00,1.00"
InputTDP002 = "30.0,1.00,9.05,1.00,8.00,1.00,8.00,1.00"
InputTDP003 = "30.0,1.00,8.00,1.00,8.00,1.00,8.00,1.00"
InputTDP004 = "30.0,1.00,8.00,1.00,8.00,1.00,8.00,1.00"
InputTDP005 = "30.0,1.00,8.00,1.00,8.00,1.00,8.00,1.00"
InputTDP006 = "30.0,1.00,8.00,1.00,8.00,1.00,8.00,1.00"
InputTDP007 = "30.0,1.00,8.00,1.00,8.00,1.00,8.00,1.00"
InputTDP008 = "30.0,1.00,8.00,1.00,8.00,1.00,8.00,1.00"
InputTDP009 = "30.0,1.00,8.00,1.00,8.00,1.00,8.00,1.00"
InputTDP010 = "30.0,1.00,8.00,1.00,8.00,1.00,8.00,1.00"
InputTDP011 = "30.0,1.00,8.00,1.00,8.00,1.00,8.00,1.00"
InputTDP012 = "30.0,1.00,8.00,1.00,8.00,1.00,8.00,1.00"
InputTDP013 = "30.0,1.00,8.00,1.00,8.00,1.00,8.00,1.00"

```

InputTDP014 = "30.0,1.00,8.00,1.00,8.00,1.00,8.00,1.00"  
InputTDP015 = "30.0,1.00,8.00,1.00,8.00,1.00,8.00,1.00"  
InputTDP016 = "30.0,1.00,8.00,1.00,8.00,1.00,8.00,1.00"  
InputTDP017 = "30.0,1.00,8.00,1.00,8.00,1.00,8.00,1.00"  
InputTDP018 = "30.0,1.00,8.00,1.00,8.00,1.00,8.00,1.00"  
InputTDP019 = "30.0,1.00,8.00,1.00,8.00,1.00,8.00,1.00"  
InputTDP020 = "30.0,1.00,8.00,1.00,8.00,1.00,8.00,1.00"  
InputTDP021 = "30.0,1.00,8.00,1.00,8.00,1.00,8.00,1.00"  
InputTDP022 = "30.0,1.00,8.00,1.00,8.00,1.00,8.00,1.00"  
InputTDP023 = "50.0,1.00,8.00,1.00,8.00,1.00,8.00,1.00"  
InputTDP024 = "50.0,1.00,8.00,1.00,8.00,1.00,8.00,1.00"  
InputTDP025 = "50.0,1.00,8.00,1.00,8.00,1.00,8.00,1.00"  
InputTDP026 = "50.0,1.00,8.00,1.00,8.00,1.00,8.00,1.00"  
InputTDP027 = "50.0,1.00,8.00,1.00,8.00,1.00,8.00,1.00"  
InputTDP028 = "50.0,1.00,8.00,1.00,8.00,1.00,8.00,1.00"  
InputTDP029 = "50.0,1.00,8.00,1.00,8.00,1.00,8.00,1.00"  
InputTDP030 = "50.0,1.00,8.00,1.00,8.00,1.00,8.00,1.00"  
InputTDP031 = "50.0,1.00,8.00,1.00,8.00,1.00,8.00,1.00"  
InputTDP032 = "50.0,1.00,8.00,1.00,8.00,1.00,8.00,1.00"

iTC=1

StartCh = 1

For iTDP=1 To NUM\_TDP Step 1

  Select Case iTDP

  Case 0

    ' do none

  Case 1

    readstring = InputTDP001

  Case 2

    readstring = InputTDP002

  Case 3

    readstring = InputTDP003

  Case 4

    readstring = InputTDP004

  Case 5

    readstring = InputTDP005

  Case 6

    readstring = InputTDP006

  Case 7

    readstring = InputTDP007

  Case 8

    readstring = InputTDP008

  Case 9

    readstring = InputTDP009

  Case 10

    readstring = InputTDP010

Case 11  
readstring = InputTDP011  
Case 12  
readstring = InputTDP012  
Case 13  
readstring = InputTDP013  
Case 14  
readstring = InputTDP014  
Case 15  
readstring = InputTDP015  
Case 16  
readstring = InputTDP016  
Case 17  
readstring = InputTDP017  
Case 18  
readstring = InputTDP018  
Case 19  
readstring = InputTDP019  
Case 20  
readstring = InputTDP020  
Case 21  
readstring = InputTDP021  
Case 22  
readstring = InputTDP022  
Case 23  
readstring = InputTDP023  
Case 24  
readstring = InputTDP024  
Case 25  
readstring = InputTDP025  
Case 26  
readstring = InputTDP026  
Case 27  
readstring = InputTDP027  
Case 28  
readstring = InputTDP028  
Case 29  
readstring = InputTDP029  
Case 30  
readstring = InputTDP030  
Case 31  
readstring = InputTDP031  
Case 32  
readstring = InputTDP032  
EndSelect

```
' Read string values to an array
SplitStr (ArrayTemp(),readstring,",",8,0)
' Assign temporary array values to sensor array
'SensorTDP(i) = ArrayTemp() 'This will not work as crbasic doesnot support 2 dimensional
arrays
```

```
' Assign sensor array values to TC array for faster calculations
Select Case ArrayTemp(1)           'switch based on sensor type
Case 10.0, 30.0, 50.0             ' Is the sensor TDP10 or TDP30 or TDP50?
  TC_Sno(iTC) = iTDP
  TC_Stype(iTC) = ArrayTemp(1)
  TC_dTM(iTC) = ArrayTemp(3)
  TC_SArea(iTC) = ArrayTemp(4)
  iTC=iTC+1
```

```
TDP_Stype(iTDP) = ArrayTemp(1)
TDP_IArea(iTDP) = ArrayTemp(2)
TDP_nCH(iTDP) = StartCh
StartCh=StartCh+1
```

```
Case 80.0                          ' Is the sensor TDP80?
  TC_Sno(iTC) = iTDP
  TC_Stype(iTC) = ArrayTemp(1) ' 113.0
  TC_dTM(iTC) = ArrayTemp(3)
  TC_SArea(iTC) = ArrayTemp(4)
  iTC=iTC+1
  TC_Sno(iTC) = iTDP
  TC_Stype(iTC) = 113.1           ' TDP80 channel B
  TC_dTM(iTC) = ArrayTemp(5)
  TC_SArea(iTC) = ArrayTemp(6)
  iTC=iTC+1
```

```
TDP_Stype(iTDP) = ArrayTemp(1)
TDP_IArea(iTDP) = ArrayTemp(2)
TDP_nCH(iTDP) = StartCh
StartCh=StartCh+2
```

```
Case 100.0                          ' Is the sensor TDP100?
  TC_Sno(iTC) = iTDP
  TC_Stype(iTC) = ArrayTemp(1) ' 113.0
  TC_dTM(iTC) = ArrayTemp(3)
  TC_SArea(iTC) = ArrayTemp(4)
  iTC=iTC+1
  TC_Sno(iTC) = iTDP
  TC_Stype(iTC) = 114.1           ' TDP100 channel B
  TC_dTM(iTC) = ArrayTemp(5)
```

```

TC_SArea(iTC) = ArrayTemp(6)
iTC=iTC+1
TC_Sno(iTC) = iTDP
TC_SType(iTC) = 114.2           ' TDP100 channel C
TC_dTM(iTC) = ArrayTemp(7)
TC_SArea(iTC) = ArrayTemp(8)
iTC=iTC+1

TDP_SType(iTDP) = ArrayTemp(1)
TDP_IArea(iTDP) = ArrayTemp(2)
TDP_nCH(iTDP) = StartCh
StartCh=StartCh+3

Case 0.00
Exit For ' End of required channels

Case Else
'Error in decoding the sensor array elements
EndSelect
Next i

' NUM_TC = iTC - 1           ' Total number of thermocouples in use

'//////////End parsing string to arrays or variables

'////////////////////////////////////
'Write setup to TABLE_SETUP
'////////////////////////////////////

'Initialize timer TIMERNO_WARMUP
Timer(TIMERNO_WARMUP,min,TIMER_RSTnSTART)

Count_Day=0
Flag_ZeroDay = True
ZDay_Count = 0
ZRun_Count = 0
' clear temporary variables
For iTC=1 To 32 Step 1
ZRun_dT0(iTC)=0
ZRun_dT1(iTC)=0
ZRun_dT2(iTC)=0
ZRun_dTAvg(iTC)=0
ZRun_dTMax(iTC)=0

ZDay_dT0(iTC)=0

```

```
ZDay_dT1(iTC)=0
ZDay_dT2(iTC)=0
ZDay_dTAvg(iTC)=0
ZDay_dTDiff(iTC)=0
ZDay_dTNew(iTC)=0
Next i
```

```
'Initially set port4 for AVR control signal OFF; now in Initialized statements below
' PortSet(4,0)
```

```
Scan(INT_SCAN,Sec,1,0)
```

```
RealTime(RealTimeArray)
'Check for top of the hour
```

```
' initialize the default (power up) conditions
```

```
If Initialized = 0 Then
```

```
  Initialized = 1
```

```
  NEWBATTCAP = 12 ' 100Ahr is max capacity the CH200 will accept
```

```
  SapHtrControlMode = "ON" 'Default mode is Sap Flow Sensor Heater ON
```

```
  PortSet(4,1)
```

```
EndIf
```

```
""""Sap Flow Heater Control""""
```

```
If SapHtrControlMode = "OFF" Then
```

```
  SapHtrControlStatus = 0
```

```
  PortSet(4,0)
```

```
EndIf
```

```
If SapHtrControlMode = "ON" Then
```

```
  SapHtrControlStatus = 1
```

```
  PortSet(4,1)
```

```
EndIf
```

```
'Condition If top of the hour
```

```
If (TimeIntoInterval (0,60,Min)) Then ' Do this only on the first pass after the top of the hour
```

```
  ' Store hourly data in table and reset accumulators, *** Update 11-19-08 MVB
```

```
  JDAY = RealTimeArray(9)
```

```
  JHM = RealTimeArray(4)*100 + RealTimeArray(5)
```

```
  CallTable(TableHR)
```

```
    'Temporary Removal***** Added Back MVB*****
```

```
  Hr_Flow=0
```

```
'Check for top of the day
```

```

If (TimeIntoInterval (0,24,hr)) Then      *** Update 11-19-08 MVB
' If top of the day, Store daily data in table and reset accumulators
' Top of the day need to store daily table
JDAY = RealTimeArray(9)
CallTable(TableDY)                        ' Temporary
Removal*****Added Back MVB *****
DY_Flow = 0

' Update day counter, this counter may be used as a public variable for other algorithms
Count_Day = Count_Day + 1

'Check for auto zero in this day and enable the flags
' number of seconds since ZERO_STARTHOUR is less than INT_SCAN*2 i.e. before the
second pass
'at the top of every hour check if it is ZERO_STARTHOUR, if so enable flags for auto zero
(run and day)
' Removed - MVB ' RealTimeSec =
RealTimeArray(4)*60*60+RealTimeArray(5)*60+RealTimeArray(6)
If ((ZERO_ENABLE) AND (ZERO_DAYINT <> 0)) Then
' Remove ' If (RealTimeSec <= (ZERO_STARTHOUR*60*60 + INT_SCAN)) Then
' Will only execute 1 x top of the day...

' Check and enable auto zero for today if necessary
If ((Count_Day <= 2) OR ((Count_Day MOD ZERO_DAYINT)=0 AND Count_Day >=
ZERO_DAYINT)) Then
'Perform auto zero on day0, day1, day2 and every day following day2 at an interval
ZERO_DAYINT
Flag_ZeroDay = True
ZRun_Count = 0
' clear temporary variables
For iTC=1 To 32 Step 1
ZRun_dT0(iTC)=0
ZRun_dT1(iTC)=0
ZRun_dT2(iTC)=0
ZRun_dTAvg(iTC)=0
ZRun_dTMax(iTC)=0
Next iTC
Else
Flag_ZeroDay = False
EndIf      ' End Count Day Check
' Removed Hour Start Check ' EndIf      ' End Time Zero Start
Hour Check
Else
Flag_ZeroDay = False
EndIf      ' End zero_enable Check

```

```

EndIf                                     ' After Top of the day Check
EndIf                                     'Condition EndIf top of the hour

If SapHtrControlStatus = 1 Then
'   If powersave option is enabled check times and perform powersave
  If (PS_ENABLE=True) Then
    RealTime(RealTimeArray)
    RealTimeMin = RealTimeArray(4)*60+RealTimeArray(5)
    If (RealTimeMin < PS_STOP) Then   PortSet(4, 0)   ' Shutdown AVR
    If (RealTimeMin >= PS_STOP) Then   PortSet(4, 1)   ' AVR ON
    If (RealTimeMin >= PS_START) Then   PortSet(4, 0)   ' Shutdown AVR
  Else
    PortSet(4, 1)                       ' If power save option is not enabled AVR ON always
  EndIf
EndIf
If SapHtrControlStatus = 0 Then PortSet(4,0)

' Measure battery voltage
Battery (BattVolts_V)
'Wiring Panel Temperature measurement LoggerTemp_C:
PanelTemp(LoggerTemp_C,_60Hz)
'read heater voltages
VoltSe(HtrV(1),2,mV5000,14,1,0,_60Hz,0.004,0)
' A 15K and 4.99K voltage divider is inline that reduces the voltage seen by the logger to 1/4th
of its actual value
' Hence a multiplier of 0.004 is applied
'           VoltDiff(HtrV(1),4,mV5000,5,True,0,_60Hz,0.001,0.0)

'Begin 60-sec Loop
If IfTime (0,60,Sec) Then

' Start GWS code VVVVVVVVVVVVVVVVVVVVVVVVVVVVVVV
'''' Set Station ID ''''
StationID = ID

'''''''''' CH200 CHARGE REGULATOR MEASUREMENTS
' Feature to enter specific battery capacity as a Public value and send to charger(s)
'Get additional values from CH200
SDI12Recorder (CH200_MX(),1,0,"M6!",1.0,0)
'If the present battery capacity isnot the same as the new battery capacity, send the new one.
If BattCap <> NEWBATTCAP Then
  SDI12command = "XC" & FormatFloat (NEWBATTCAP, "%4.1f") & "!"
  SDI12Recorder (SDI12result,1,0,SDI12command,1.0,0)
EndIf

```



\*\*\*\*\* CH200 CHARGE REGULATOR MEASUREMENTS  
SDI12Recorder (CH200\_M0(),1,0,"MC!",1.0,0)

' Compute running Power and daily running total AmpHours/Day values for each current measurement.

LoadPwr\_W = CH200BattVolts\_V \* LoadCrnt\_A

ChargePwr\_W = SolarPanel\_V \* SolarPanel\_A

' Divide each 1 minute Amp sample by 1440 sample/day so that the total at the end of the day is to get avg current for the day

' then multiply by 24 Hr/day to get Ahr/Day. or divide by 60 because 24/1440 = 1/60

' Separate and sum each the positive and negative currents into and out of the battery to get the total Ahr in/out for the day.

' Sample hourly and daily, then zero at end of the day.

If BattCrnt\_A > 0 Then DlyBatCrntIn\_AHr = DlyBatCrntIn\_AHr + BattCrnt\_A/60

If BattCrnt\_A < 0 Then DlyBatCrntOut\_AHr = DlyBatCrntOut\_AHr + BattCrnt\_A/60

\*\*\*\*\* READ INW or CSI SDI-12 Pressure Transducer  
SDI12Recorder (PT1Data(),5,1,"M!",1.0,0)

' convert water heights in psi to cm (70.307 cm/psi)

WaterHt1\_cm = WaterHt1\_psi \* 70.307

'Convert Water Height in cm to ft. (0.0328 ft/cm)

WaterHt1\_ft = WaterHt1\_cm \* 0.0328

EndIf 'End of 60-second scan loop

' End GWS code ^^^^^^^^^^^^^^^^^^^^^^^^^^^^^^^^^^^^^

'Calculate warmup time condition; all the warmup statuses are based on Heater voltage Vin1

'TIMERNO\_WARMUP

If (HtrV(1) < HTROFF\_VOLT)

Timer(TIMERNO\_WARMUP,min,TIMER\_STOPnRST) 'Stop

and reset timer TIMERNO\_WARMUP if heater voltage HtrV(1) < 0.5V

Flag\_HtrOff = TRUE

'HeaterOff flag True

Else

If (Flag\_HtrOff = TRUE)

Timer(TIMERNO\_WARMUP,min,TIMER\_RSTnSTART) 'Reset and start timer

TIMERNO\_WARMUP if heater voltage HtrV(1) >= 0.5V and just started

EndIf

Flag\_HtrOff = FALSE

'HeaterOff flag True

EndIf

'Turn AM16/32 Multiplexer On

PortSet(2,1)

Delay(0,150,mSec)

iTC=1

```

SubScan(100000,uSec,NUM_TC)                                'Added delays MVB
4-20-2008
'Switch to next AM16/32 Multiplexer channel
PulsePort(3,35000)                                         'Maximum Delay Added also
'Generic Differential Voltage measurements dTC on the AM16/32 Multiplexer:
VoltDiff(TC_dTC(iTC),1,mV2_5C,1,1,0,_60Hz,25.0,0.0)      ' reads
mV from the sensor and calculate dT = mV *25.0
iTC=iTC+1
NextSubScan
'Turn AM16/32 Multiplexer Off
PortSet(2,0)
Delay(0,150,mSec)
'Store average of dT values in TableDT - internal program / temporary table
CallTable(TableDT)

'Average the dT values at the average interval (INT_AVG) and compute sapflow
If TimeIntoInterval(0,INT_AVG,min) Then

' Call subroutine to calculate sapflow on each thermocouple
For iTC = 1 To NUM_TC Step 1
  TC_dTCa(iTC) = TableDT.TC_dTC_AVG(iTC,1)
  ' read average of dTC from TableDT

' Initialize variables
TC_Status(iTC) = TCSTAT_OKV
TC_Vel(iTC)=0
TC_Flow(iTC)=0

Do ' this is used to obtain a way for CONTINUE statement in C
' Start TC-SapFlow computations
If ((HtrV(1)<HTROFF_VOLT OR TC_dTCa(iTC) = NAN) AND
TC_Status(iTC)=TCSTAT_OKV) Then
  TC_Status(iTC) = TCSTAT_OFF
  ExitDo
EndIf

If ( (TC_dTCa(iTC) > 62 OR TC_dTCa(iTC) < -62) AND
TC_Status(iTC)=TCSTAT_OKV) Then
  TC_Status(iTC) = TCSTAT_FAULT
  ExitDo
EndIf

If (TC_dTCa(iTC) = 0 AND TC_Status(iTC)=TCSTAT_OKV) Then
  TC_Status(iTC) = TCSTAT_MERR

```

```

ExitDo
EndIf
If (TC_dTCa(iTC) < 0 AND TC_Status(iTC)=TCSTAT_OKV) Then
  TC_Status(iTC) = TCSTAT_REV
ExitDo
EndIf

If (TC_dTM(iTC) < TC_dTCa(iTC) AND TC_Status(iTC)=TCSTAT_OKV) Then
  TC_Status(iTC) = TCSTAT_ZERO
ExitDo
Else If (TC_Status(iTC)=TCSTAT_OKV)
  KPar = ((TC_dTM(iTC) - TC_dTCa(iTC))/ TC_dTCa(iTC))
  ' constant no units
  If KPar < 0 Then ' only double checking not necessary
    TC_Status(iTC) = TCSTAT_ZERO
    ExitDo
  Else
    ' Updated Vel to cm/h, not sec. because FP2 format would not show values,
nor is it standard!!
    TC_Vel(iTC) = 0.0119 * (KPar ^ 1.231)*3600
Velocity in cm/h , MVB- 11-18-08
    TC_Flow(iTC) = TC_SArea(iTC) * TC_Vel(iTC)
SapFlow in g/hr
  EndIf
EndIf

' check for maxflow
If ( (TC_dTCa(iTC) <= DTMIN OR TC_Vel(iTC) > 200) AND
TC_Status(iTC)=TCSTAT_OKV) Then
  TC_Status(iTC) = TCSTAT_MAX
ExitDo
EndIf
ExitDo
Loop
' check for warmup time
Htr_ON_Time = Timer(TIMERNO_WARMUP,min,TIMER_READONLY)
If (Htr_ON_Time < WARMUP_MIN ) Then
  TC_Status(iTC) = TCSTAT_WARM
EndIf

If (TC_Status(iTC) <> TCSTAT_OKV) Then
  'Make all the storing variables to zero//// If necessary

EndIf
Next iTC

```

'Call Data Tables and Store Data

RealTime(RealTimeArray)

JDAY = RealTimeArray(9)

JHM = RealTimeArray(4)\*100+RealTimeArray(5)

CallTable(TableTC)

'This was temporarily removed MVB put back 4-21

'Convert thermocouple sapflow to TDP sensor sapflow

' Not implemented ' currently the code works for TDP10/30/50 sensors

For iTDP = 1 To NUM\_TDP Step 1

StartCh = TDP\_nCH(iTDP)

If (StartCh > NUM\_TC)

ExitFor

EndIf

If ((TDP\_SType(iTDP) = TDP10) OR (TDP\_SType(iTDP) = TDP30) OR  
(TDP\_SType(iTDP) = TDP50)) Then

TDP\_Flow(iTDP) = TC\_Flow(StartCh)

TDP\_Status(iTDP) = TC\_Status(StartCh)

ElseIf (TDP\_SType(iTDP) = TDP80)

If ((TC\_Status(StartCh)=TC\_Status(StartCh+1)) AND  
(TC\_Status(StartCh)=TCSTAT\_OKV)) Then

TDP\_Flow(iTDP) = TC\_Flow(StartCh) + TC\_Flow(StartCh+1)

TDP\_Status(iTDP) = TC\_Status(StartCh)

ElseIf ((TC\_Status(iTC)= TC\_Status(iTC+1))) Then

TDP\_Flow(iTDP) = 0

TDP\_Status(iTDP) = TC\_Status(StartCh)

Else

TDP\_Flow(iTDP) = 0

TDP\_Status(iTDP) = TDPSTAT\_NALL

EndIf

ElseIf (TDP\_SType(iTDP) = TDP100)

If ((TC\_Status(StartCh)= TC\_Status(StartCh+1)) AND  
(TC\_Status(StartCh)=TC\_Status(StartCh+2)) AND (TC\_Status(StartCh)=TCSTAT\_OKV))  
Then

TDP\_Flow(iTDP) = TC\_Flow(StartCh) + TC\_Flow(StartCh+1) + TC\_Flow(StartCh+2)

TDP\_Status(iTDP) = TC\_Status(StartCh)

ElseIf ((TC\_Status(StartCh)= TC\_Status(StartCh+1)) AND  
(TC\_Status(StartCh)=TC\_Status(StartCh+2))) Then

TDP\_Flow(iTDP) = 0

TDP\_Status(iTDP) = TC\_Status(StartCh)

Else

```

    TDP_Flow(iTDP) = 0
    TDP_Status(iTDP) = TDPSTAT_NALL
  EndIf
Else
  ' Problem in assigning TC to TDP
  TDP_Flow(iTDP) = 0
  TDP_Status(iTDP) = TDPSTAT_ERRCH
EndIf
Next iTDP

'Calculate indexes for each sensor not thermocouple
For iTDP = 1 To NUM_TDP Step 1
  'Index sapflow to field
  TDP_FlowIx(iTDP) = TDP_Flow(iTDP) / TDP_IArea(iTDP) * FIELDINDEX
Next iTDP

'Perform Voting on Indexed sapflows
' vote out 2 sensors if number of sensors with OKV >6
'or vote out 1 sensor if number of sensors with OKV >2 and <=6
'or vote out none if number of sensors with OKV <=2
'Count the number of sensors currently voting
'////////////////Vote out first one if necessary
Count_OKV = 0
Count_OKN=0
For iTDP = 1 To NUM_TDP Step 1
  If (TDP_Status(iTDP) = TDPSTAT_OKV) Then
    Count_OKV = Count_OKV +1
  EndIf
Next iTDP
'////////////////Vote out first one
If (Count_OKV > 6) Then
  Call VoteOut1
EndIf
'////////////////Vote out second one if necessary
'Count the number of sensors currently voting
Count_OKV = 0
For iTDP = 1 To NUM_TDP Step 1
  If (TDP_Status(iTDP) = TDPSTAT_OKV) Then
    Count_OKV = Count_OKV +1
  EndIf
Next iTDP

If (Count_OKV > 2) Then
  Call VoteOut1
EndIf
'////////////////////////////////////

```

```

RealTime(RealTimeArray)
JDAY = RealTimeArray(9)
JHM = RealTimeArray(4)*100+RealTimeArray(5)
CallTable(TableTDP)
removal*****added back MVB*****
'Calculate average indexed sapflow of the voting sensors
Flow_AvgIx = 0
Count_OKV = 0
For iTDP = 1 To NUM_TDP Step 1
  If (TDP_Status(iTDP)=TDPSTAT_OKV) Then
    Flow_AvgIx = Flow_AvgIx + TDP_FlowIx(iTDP)
    Count_OKV = Count_OKV +1
  EndIf
Next iTDP
Flow_AvgIx = Flow_AvgIx/Count_OKV
If Flow_AvgIx < 0 Then
  Flow_AvgIx = 0
EndIf
Flow_Int = Flow_AvgIx * INT_AVG / 60
Instantaneous flow rate
Hr_Flow = Hr_Flow + Flow_Int
hourly accumulator
DY_Flow = DY_Flow + Hr_Flow
Update daily accumulator

' Perform auto zero - running
'add the conditions for autozero enabled and interval here
' Check is autozero is enabled
RealTime(RealTimeArray)
RealTimeMin = RealTimeArray(4)*60+RealTimeArray(5)
If (( Flag_ZeroDay = True) AND (RealTimeMin >= ZERO_STARTHOUR*60) AND
(RealTimeMin <= ZERO_STOPHOUR*60)) Then
  ' Call Subroutine for compuring dT running averages
  Call AutoZeroRun
  '
  CallTable(TableZRU)
  ***** Not needed after 11-18-08
EndIf
' End Autozero running

'Perform autozero day
RealTime(RealTimeArray)
RealTimeMin = RealTimeArray(4)*60+RealTimeArray(5)
If ((Flag_ZeroDay = True) AND (RealTimeMin = ZERO_STOPHOUR*60)) Then
  ' Call subroutine for computing new dTM
  Call AutoZeroDay

```

'Temporary

' Hourly component of the

' Update

'

```

Flag_ZeroDay = False      'Disable autozero until midnight or logger power is reset
'                          CallTable(TableZDa)      *****
Not needed after 11-18-08
EndIf                      ' End Autozero day

EndIf                      'End of If TimeIntoInterval - INT_AVG

' GWS Tables VVVVVVVVVVVVVVVVVVVVVVV
CallTable HourlyDiag
CallTable QuarterHourlyWater
CallTable Daily
CallTable HrlyClimate
CallTable DailyRaw
' End GWS Tables ^^^^^^^^^^^^^^^

If IfTime (0,1440,Min) Then
  DlyBatCrtIn_AHr = 0
  DlyBatCrtOut_AHr = 0
EndIf

NextScan
EndProg

```

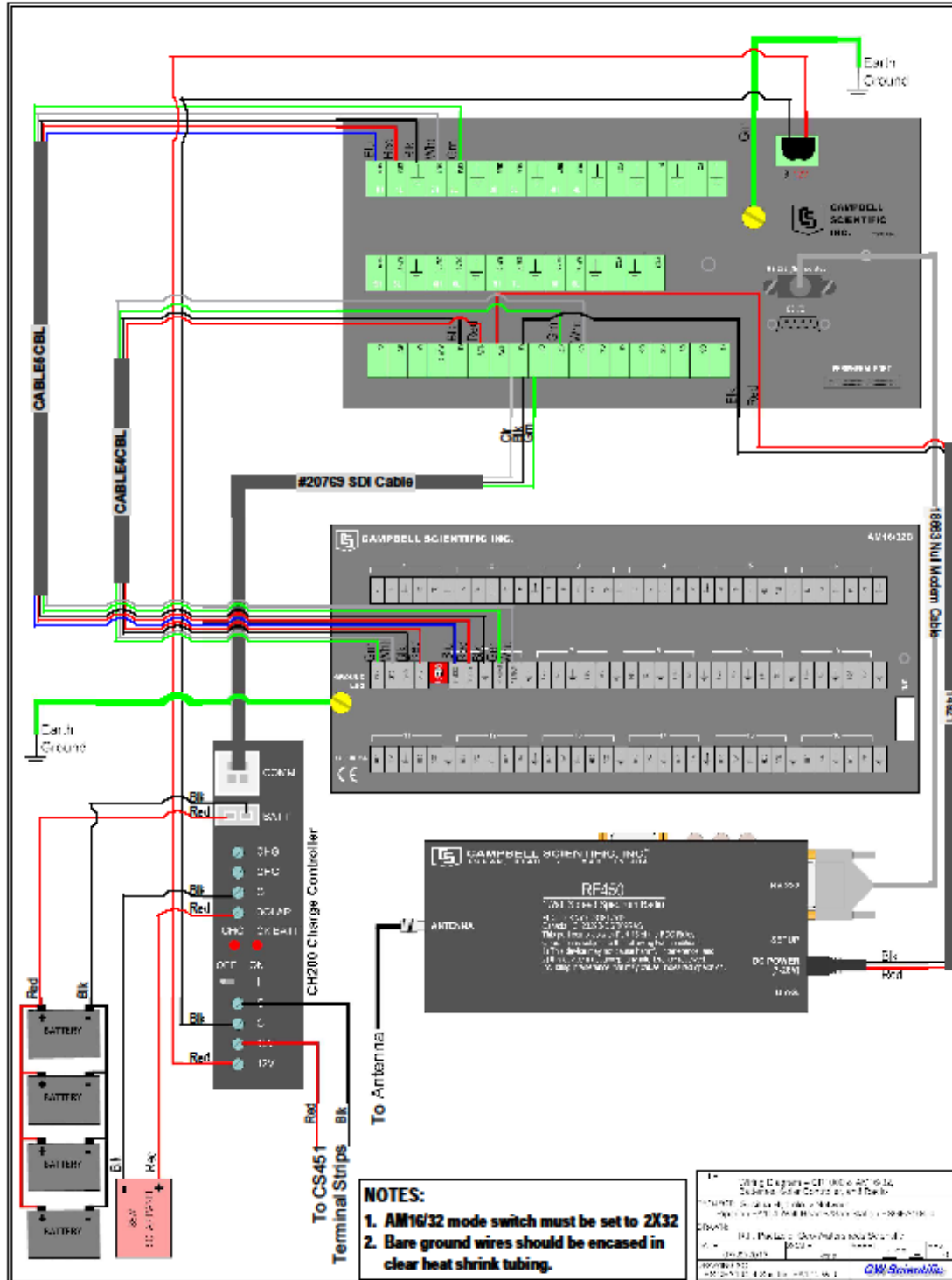


Figure C-14. ESGFA104-4 Sheet 1 (Data Logger, Power, Radio, Multiplexer).



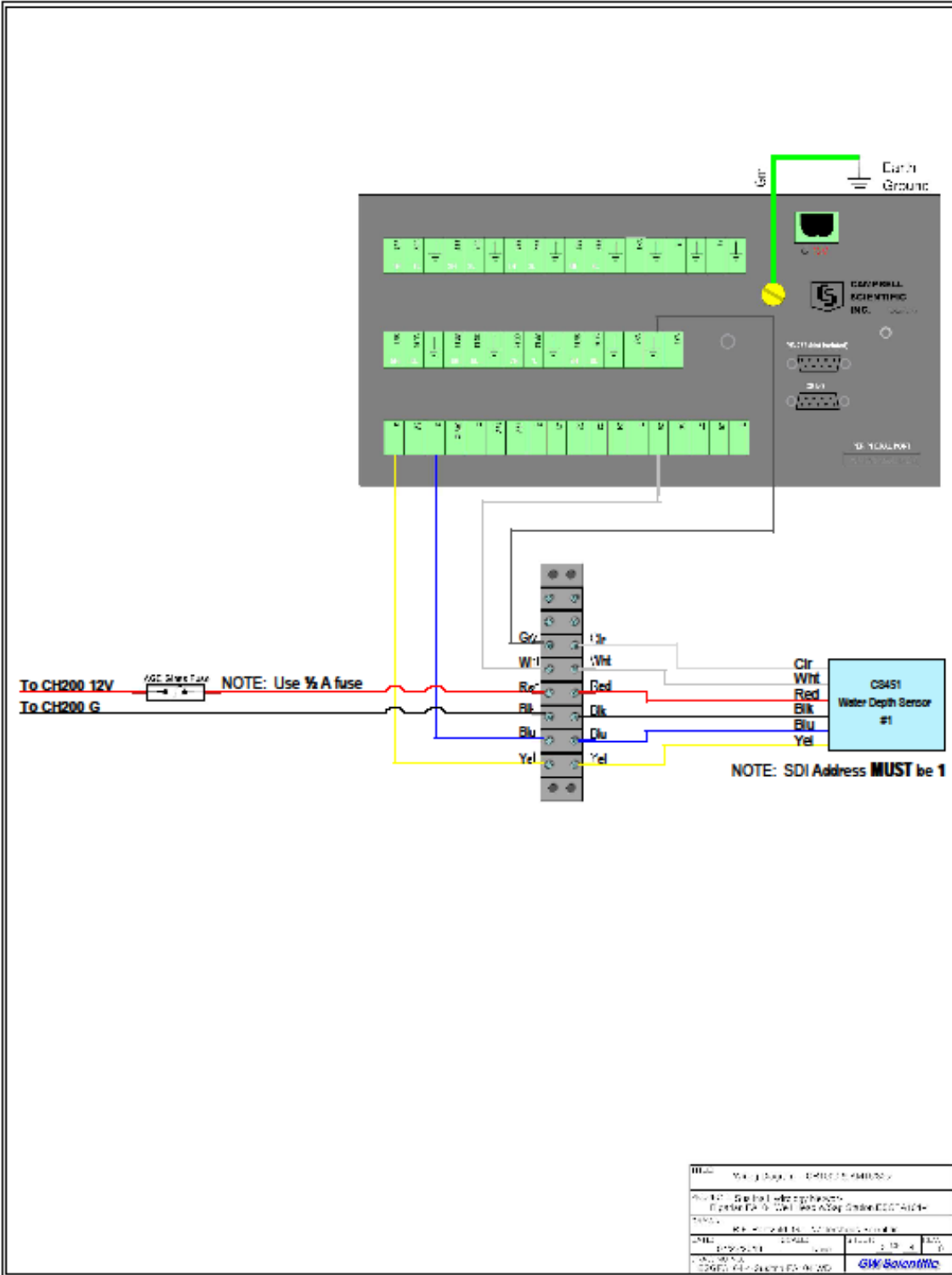


Figure C-15. ESGFA104-4 Sheet 2 (Data Logger, CS Sensors).

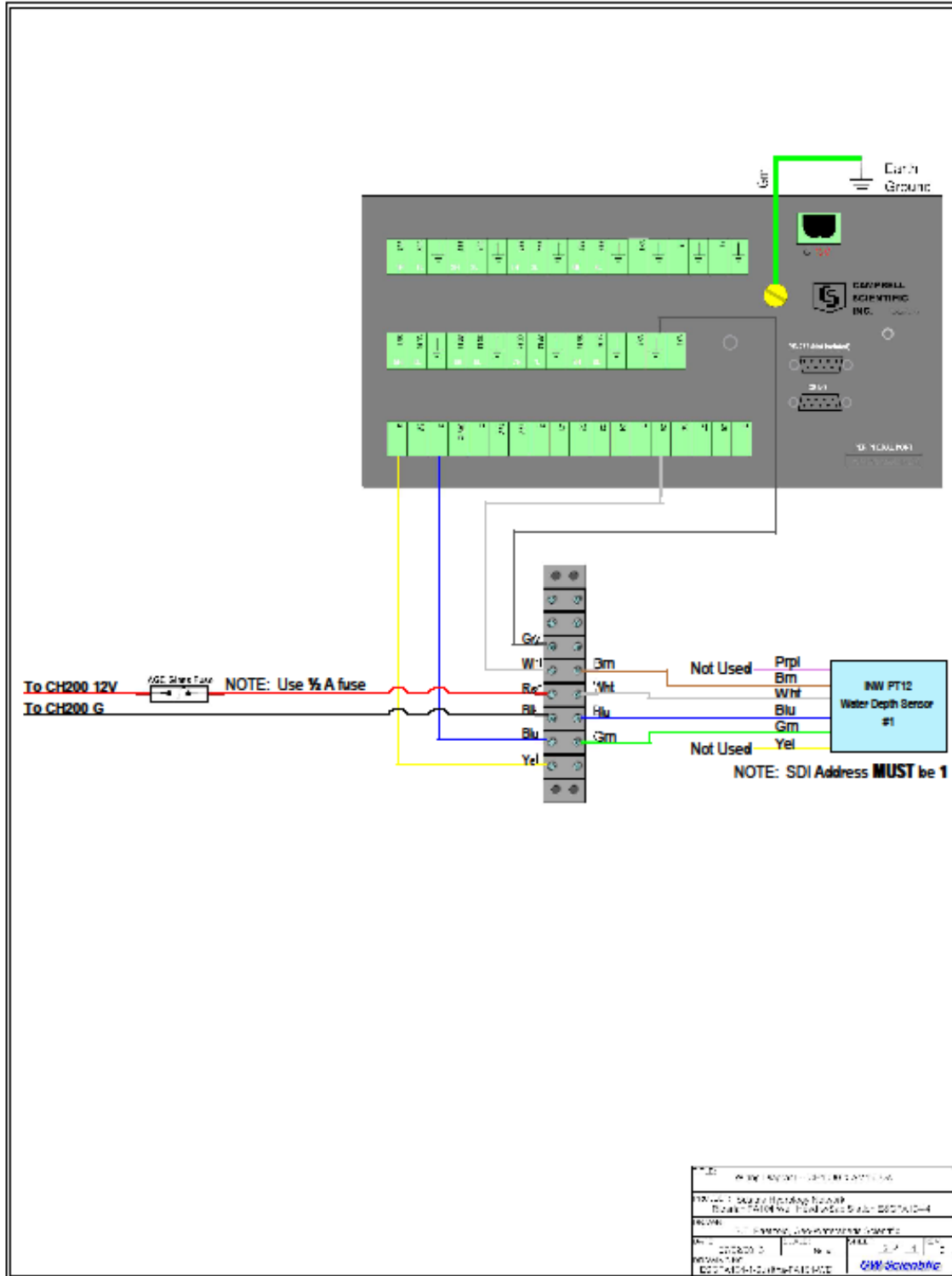


Figure C-16. ESGFA104-4 Sheet 2alt (Data Logger, INW Sensors).



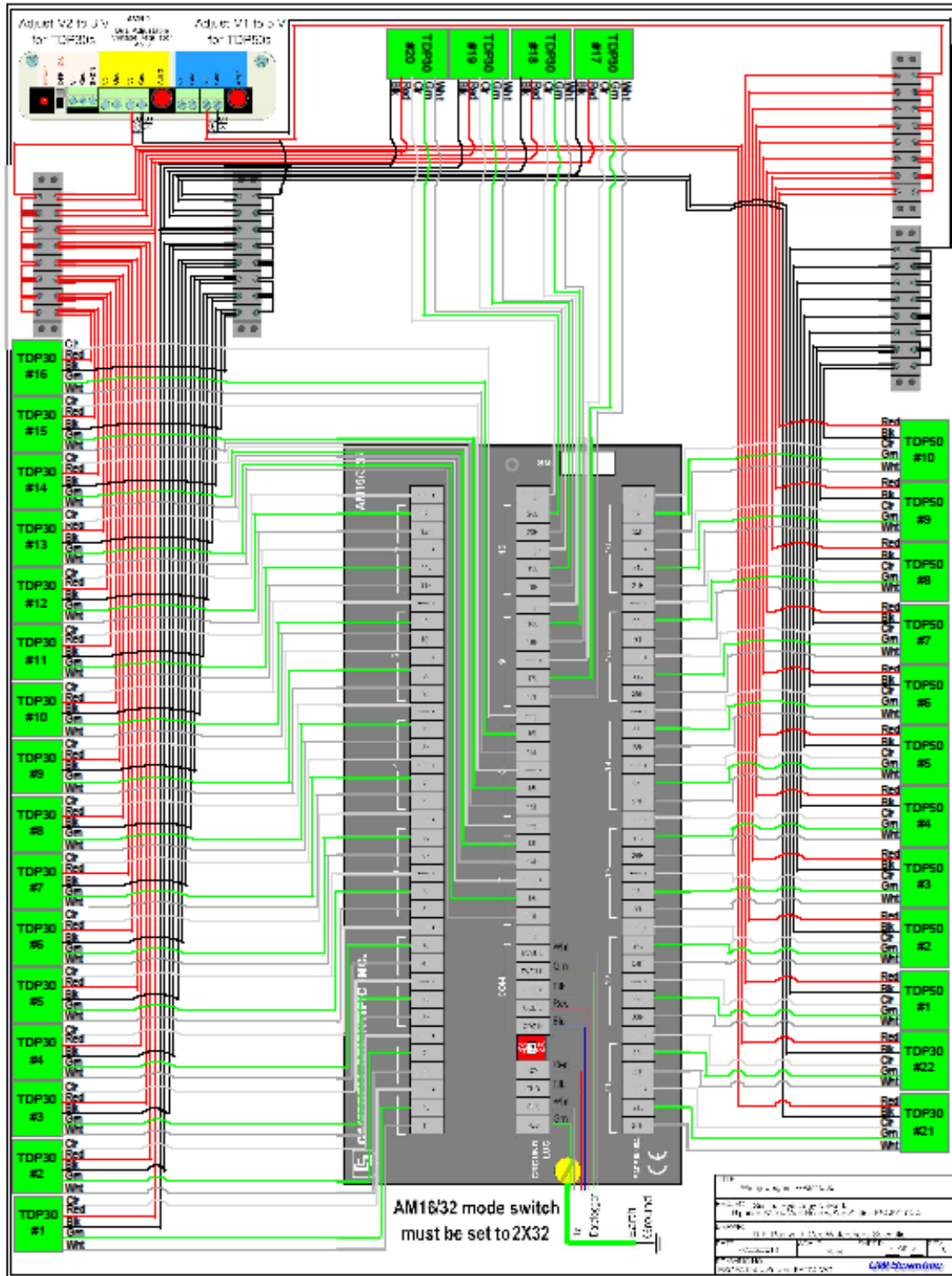


Figure C-18. ESGFA104-4 Sheet 4 (Multiplexer, Sap Flow Sensors).





Public Cond1T\_C  
 Public Cond2\_mS\_cm, Cond2\_uS\_cm  
 Public Cond2TC\_mS\_cm, Cond2TC\_uS\_cm  
 Public Cond2T\_C

Public Therm\_kOhm(24), Temp\_C(24) ' two GWS soil temp strings

Dim Initialized  
 Dim Rs1,Rs2  
 Dim therm(24),D(24),i,j

Alias PT1Data(1) = WaterHt1\_psi  
 Alias PT1Data(2) = WaterT1\_C  
 Alias PT2Data(1) = WaterHt2\_psi  
 Alias PT2Data(2) = WaterT2\_C  
 Alias PT3Data(1) = WaterHt3\_psi  
 Alias PT3Data(2) = WaterT3\_C  
 Alias PT4Data(1) = WaterHt4\_psi  
 Alias PT4Data(2) = WaterT4\_C

Alias CH200\_M0(1)=CH200BattVolts\_V 'Battery voltage: VDC  
 Alias CH200\_M0(2)=BattCrnt\_A 'Current going into, or out of, the battery: Amps  
 Alias CH200\_M0(3)=LoadCrnt\_A 'Current going to the load: Amps  
 Alias CH200\_M0(4)=SolarPanel\_V 'Voltage coming into the charger: VDC  
 Alias CH200\_M0(5)=SolarPanel\_A 'Current coming into the charger: Amps  
 Alias CH200\_M0(6)=Chgr\_Tmp\_C 'Charger temperature: Celsius  
 Alias CH200\_M0(7)=Chgr\_State 'Charging state: 2=Cycle, 3=Float, 1=Current Limited, or  
 0=None  
 Alias CH200\_M0(8)=Chgr\_Source 'Charging source: 0=None, 1=Solar, or 2=AC  
 Alias CH200\_M0(9)=Ck\_Batt 'Check battery error: 0=normal, 1=check battery

Alias Temp\_C(1) = SoilT\_5cm\_C  
 Alias Temp\_C(2) = SoilT\_10cm\_C  
 Alias Temp\_C(3) = SoilT\_15cm\_C  
 Alias Temp\_C(4) = SoilT\_20cm\_C  
 Alias Temp\_C(5) = SoilT\_30cm\_C  
 Alias Temp\_C(6) = SoilT\_40cm\_C  
 Alias Temp\_C(7) = SoilT\_50cm\_C  
 Alias Temp\_C(8) = SoilT\_60cm\_C  
 Alias Temp\_C(9) = SoilT\_80cm\_C  
 Alias Temp\_C(10) = SoilT\_100cm\_C  
 Alias Temp\_C(11) = SoilT\_120cm\_C  
 Alias Temp\_C(12) = SoilT\_150cm\_C

Alias Temp\_C(13) = SoilT2\_5cm\_C

Alias Temp\_C(14) = SoilT2\_10cm\_C  
Alias Temp\_C(15) = SoilT2\_15cm\_C  
Alias Temp\_C(16) = SoilT2\_20cm\_C  
Alias Temp\_C(17) = SoilT2\_30cm\_C  
Alias Temp\_C(18) = SoilT2\_40cm\_C  
Alias Temp\_C(19) = SoilT2\_50cm\_C  
Alias Temp\_C(20) = SoilT2\_60cm\_C  
Alias Temp\_C(21) = SoilT2\_80cm\_C  
Alias Temp\_C(22) = SoilT2\_100cm\_C  
Alias Temp\_C(23) = SoilT2\_120cm\_C  
Alias Temp\_C(24) = SoilT2\_150cm\_C

## 'Hourly Diagnostics Table

DataTable (HourlyDiag,1,-1)

DataInterval (0,60,Min,0)

Sample (1,StationID,fp2)

## 'BATTERY VOLTS (V)

Sample (1,BattVolts\_V,FP2)

Average (1,BattVolts\_V,FP2,False)

Maximum (1,BattVolts\_V,FP2,False,False)

Minimum (1,BattVolts\_V,FP2,False,False)

## 'BATTERY CURRENT (A)

Sample (1,CH200\_M0(2),FP2)

Average (1,CH200\_M0(2),FP2,False)

Maximum (1,CH200\_M0(2),FP2,False,False)

Minimum (1,CH200\_M0(2),FP2,False,False)

## 'LOAD CURRENT (A)

Sample (1,CH200\_M0(3),FP2)

Average (1,CH200\_M0(3),FP2,False)

Maximum (1,CH200\_M0(3),FP2,False,False)

Minimum (1,CH200\_M0(3),FP2,False,False)

## 'SOLAR PANEL VOLTS (V)

Sample (1,CH200\_M0(4),FP2)

Average (1,CH200\_M0(4),FP2,False)

Maximum (1,CH200\_M0(4),FP2,False,False)

Minimum (1,CH200\_M0(4),FP2,False,False)

## 'SOLAR PANEL CURRENT (A)

Sample (1,CH200\_M0(5),FP2)

Average (1,CH200\_M0(5),FP2,False)

Maximum (1,CH200\_M0(5),FP2,False,False)



Minimum (1,CH200\_M0(5),FP2,False,False)

Average (1,LoggerTemp\_C,FP2,False) 'Logger Temperature (deg C)

Average (1,CH200\_M0(6),FP2,False) 'Charge Regulator Temperature (deg C)

Sample (1,NEWBATTCAP,FP2)

Sample (1,BattCap,FP2)

Sample (1,DlyBatCrtIn\_AHr,FP2)

Sample (1,DlyBatCrtOut\_AHr,FP2)

Average (1,ChargePwr\_W,FP2,False)

Maximum (1,ChargePwr\_W,FP2,False,False)

Minimum (1,ChargePwr\_W,FP2,False,False)

Average (1,LoadPwr\_W,FP2,False)

Maximum (1,LoadPwr\_W,FP2,False,False)

Minimum (1,LoadPwr\_W,FP2,False,False)

'Charger state

Sample (1,CH200\_M0(7),FP2)

EndTable

'15-minute Water Ttable

DataTable (QuarterHourlyWater,1,-1)

DataInterval(0,15,Min,0)

Sample (1,StationID,fp2)

Sample (1,WaterHt1\_cm,FP2)

Average (1,WaterHt1\_cm,FP2,False)

Maximum (1,WaterHt1\_cm,FP2,False,False)

Minimum (1,WaterHt1\_cm,FP2,False,False)

Sample (1,WaterHt2\_cm,FP2)

Average (1,WaterHt2\_cm,FP2,False)

Maximum (1,WaterHt2\_cm,FP2,False,False)

Minimum (1,WaterHt2\_cm,FP2,False,False)

Sample (1,WaterHt3\_cm,FP2)

Average (1,WaterHt3\_cm,FP2,False)

Maximum (1,WaterHt3\_cm,FP2,False,False)

Minimum (1,WaterHt3\_cm,FP2,False,False)

Sample (1,WaterHt4\_cm,FP2)

Average (1,WaterHt4\_cm,FP2,False)  
Maximum (1,WaterHt4\_cm,FP2,False,False)  
Minimum (1,WaterHt4\_cm,FP2,False,False)

Sample (1,WaterHt1\_ft,FP2)  
Average (1,WaterHt1\_ft,FP2,False)  
Maximum (1,WaterHt1\_ft,FP2,False,False)  
Minimum (1,WaterHt1\_ft,FP2,False,False)

Sample (1,WaterHt2\_ft,FP2)  
Average (1,WaterHt2\_ft,FP2,False)  
Maximum (1,WaterHt2\_ft,FP2,False,False)  
Minimum (1,WaterHt2\_ft,FP2,False,False)

Sample (1,WaterHt3\_ft,FP2)  
Average (1,WaterHt3\_ft,FP2,False)  
Maximum (1,WaterHt3\_ft,FP2,False,False)  
Minimum (1,WaterHt3\_ft,FP2,False,False)

Sample (1,WaterHt4\_ft,FP2)  
Average (1,WaterHt4\_ft,FP2,False)  
Maximum (1,WaterHt4\_ft,FP2,False,False)  
Minimum (1,WaterHt4\_ft,FP2,False,False)

Sample (1,WaterT1\_C,FP2)  
Average (1,WaterT1\_C,FP2,False)  
Maximum (1,WaterT1\_C,FP2,False,False)  
Minimum (1,WaterT1\_C,FP2,False,False)

Sample (1,WaterT2\_C,FP2)  
Average (1,WaterT2\_C,FP2,False)  
Maximum (1,WaterT2\_C,FP2,False,False)  
Minimum (1,WaterT2\_C,FP2,False,False)

Sample (1,WaterT3\_C,FP2)  
Average (1,WaterT3\_C,FP2,False)  
Maximum (1,WaterT3\_C,FP2,False,False)  
Minimum (1,WaterT3\_C,FP2,False,False)

Sample (1,WaterT4\_C,FP2)  
Average (1,WaterT4\_C,FP2,False)  
Maximum (1,WaterT4\_C,FP2,False,False)  
Minimum (1,WaterT4\_C,FP2,False,False)

Sample (1,WaterHt1\_psi,FP2)  
Average (1,WaterHt1\_psi,FP2,False)

Maximum (1,WaterHt1\_psi,FP2,False,False)  
Minimum (1,WaterHt1\_psi,FP2,False,False)

Sample (1,WaterHt2\_psi,FP2)  
Average (1,WaterHt2\_psi,FP2,False)  
Maximum (1,WaterHt2\_psi,FP2,False,False)  
Minimum (1,WaterHt2\_psi,FP2,False,False)

Sample (1,WaterHt3\_psi,FP2)  
Average (1,WaterHt3\_psi,FP2,False)  
Maximum (1,WaterHt3\_psi,FP2,False,False)  
Minimum (1,WaterHt3\_psi,FP2,False,False)

Sample (1,WaterHt4\_psi,FP2)  
Average (1,WaterHt4\_psi,FP2,False)  
Maximum (1,WaterHt4\_psi,FP2,False,False)  
Minimum (1,WaterHt4\_psi,FP2,False,False)

Sample (1,Cond1TC\_mS\_cm,FP2)  
Average (1,Cond1TC\_mS\_cm,FP2,False)  
Maximum (1,Cond1TC\_mS\_cm,FP2,False,False)  
Minimum (1,Cond1TC\_mS\_cm,FP2,False,False)

Sample (1,Cond2TC\_mS\_cm,FP2)  
Average (1,Cond2TC\_mS\_cm,FP2,False)  
Maximum (1,Cond2TC\_mS\_cm,FP2,False,False)  
Minimum (1,Cond2TC\_mS\_cm,FP2,False,False)

Average (1,Cond1T\_C,FP2,False)  
Maximum (1,Cond1T\_C,FP2,False,False)  
Minimum (1,Cond1T\_C,FP2,False,False)

Average (1,Cond2T\_C,FP2,False)  
Maximum (1,Cond2T\_C,FP2,False,False)  
Minimum (1,Cond2T\_C,FP2,False,False)

EndTable

' Hourly Raw Table

DataTable (HourlyRaw,1,-1)  
DataInterval(0,60,Min,0)  
Sample (1,StationID,fp2)

Sample (1,Rs1,FP2)  
Average (1,Rs1,FP2,False)

Sample (1, Rs2, FP2)  
Average (1, Rs2, FP2, False)

Sample (24, Therm\_kOhm(), FP2)  
Average (24, Therm\_kOhm(), FP2, False)  
EndTable

'Daily Output Table

DataTable (Daily, 1, -1)  
DataInterval(0, 1440, Min, 0)  
Sample (1, StationID, fp2)

Average (1, WaterHt1\_cm, FP2, False)  
Maximum (1, WaterHt1\_cm, FP2, False, False)  
Minimum (1, WaterHt1\_cm, FP2, False, False)

Average (1, WaterHt2\_cm, FP2, False)  
Maximum (1, WaterHt2\_cm, FP2, False, False)  
Minimum (1, WaterHt2\_cm, FP2, False, False)

Average (1, WaterHt3\_cm, FP2, False)  
Maximum (1, WaterHt3\_cm, FP2, False, False)  
Minimum (1, WaterHt3\_cm, FP2, False, False)

Average (1, WaterHt4\_cm, FP2, False)  
Maximum (1, WaterHt4\_cm, FP2, False, False)  
Minimum (1, WaterHt4\_cm, FP2, False, False)

Average (1, WaterHt1\_ft, FP2, False)  
Maximum (1, WaterHt1\_ft, FP2, False, False)  
Minimum (1, WaterHt1\_ft, FP2, False, False)

Average (1, WaterHt2\_ft, FP2, False)  
Maximum (1, WaterHt2\_ft, FP2, False, False)  
Minimum (1, WaterHt2\_ft, FP2, False, False)

Average (1, WaterHt3\_ft, FP2, False)  
Maximum (1, WaterHt3\_ft, FP2, False, False)  
Minimum (1, WaterHt3\_ft, FP2, False, False)

Average (1, WaterHt4\_ft, FP2, False)  
Maximum (1, WaterHt4\_ft, FP2, False, False)  
Minimum (1, WaterHt4\_ft, FP2, False, False)

Average (1,WaterT1\_C,FP2,False)  
Maximum (1,WaterT1\_C,FP2,False,False)  
Minimum (1,WaterT1\_C,FP2,False,False)

Average (1,WaterT2\_C,FP2,False)  
Maximum (1,WaterT2\_C,FP2,False,False)  
Minimum (1,WaterT2\_C,FP2,False,False)

Average (1,WaterT3\_C,FP2,False)  
Maximum (1,WaterT3\_C,FP2,False,False)  
Minimum (1,WaterT3\_C,FP2,False,False)

Average (1,WaterT4\_C,FP2,False)  
Maximum (1,WaterT4\_C,FP2,False,False)  
Minimum (1,WaterT4\_C,FP2,False,False)

Average (1,WaterHt1\_psi,FP2,False)  
Maximum (1,WaterHt1\_psi,FP2,False,False)  
Minimum (1,WaterHt1\_psi,FP2,False,False)

Average (1,WaterHt2\_psi,FP2,False)  
Maximum (1,WaterHt2\_psi,FP2,False,False)  
Minimum (1,WaterHt2\_psi,FP2,False,False)

Average (1,WaterHt3\_psi,FP2,False)  
Maximum (1,WaterHt3\_psi,FP2,False,False)  
Minimum (1,WaterHt3\_psi,FP2,False,False)

Average (1,WaterHt4\_psi,FP2,False)  
Maximum (1,WaterHt4\_psi,FP2,False,False)  
Minimum (1,WaterHt4\_psi,FP2,False,False)

Average (1,Cond1TC\_mS\_cm,FP2,False)  
Maximum (1,Cond1TC\_mS\_cm,FP2,False,False)  
Minimum (1,Cond1TC\_mS\_cm,FP2,False,False)

Average (1,Cond2TC\_mS\_cm,FP2,False)  
Maximum (1,Cond2TC\_mS\_cm,FP2,False,False)  
Minimum (1,Cond2TC\_mS\_cm,FP2,False,False)

Average (1,Cond1T\_C,FP2,False)  
Maximum (1,Cond1T\_C,FP2,False,False)  
Minimum (1,Cond1T\_C,FP2,False,False)

Average (1,Cond2T\_C,FP2,False)  
Maximum (1,Cond2T\_C,FP2,False,False)  
Minimum (1,Cond2T\_C,FP2,False,False)

Average (12,SoilT\_5cm\_C,FP2,False)  
Average (12,SoilT2\_5cm\_C,FP2,False)  
EndTable

'Hourly Climate Table (for Current Conditions Table on Web)  
' Size limited to 96 data values or 4 days worth.

DataTable (HrlyClimate,1,96)  
DataInterval (0,60,Min,0)  
Sample (1,StationID,fp2)

Sample (1,WaterHt1\_cm,FP2)  
Sample (1,WaterHt1\_ft,FP2)  
Sample (1,WaterHt1\_psi,FP2)  
Sample (1,WaterT1\_C,FP2)

Sample (1,WaterHt2\_cm,FP2)  
Sample (1,WaterHt2\_ft,FP2)  
Sample (1,WaterHt2\_psi,FP2)  
Sample (1,WaterT2\_C,FP2)

Sample (1,WaterHt3\_cm,FP2)  
Sample (1,WaterHt3\_ft,FP2)  
Sample (1,WaterHt3\_psi,FP2)  
Sample (1,WaterT3\_C,FP2)

Sample (1,WaterHt4\_cm,FP2)  
Sample (1,WaterHt4\_ft,FP2)  
Sample (1,WaterHt4\_psi,FP2)  
Sample (1,WaterT4\_C,FP2)

Sample (1,Cond1TC\_mS\_cm,FP2)  
Sample (1,Cond2TC\_mS\_cm,FP2)

Sample (1,Cond1T\_C,FP2)  
Sample (1,Cond2T\_C,FP2)

EndTable

'Hourly Climate Table (for Current Conditions Table on Web)

DataTable (HourlySubs,1,-1)  
DataInterval (0,60,Min,0)

Sample (1,StationID,fp2)

Sample (12,SoilT\_5cm\_C,FP2)  
Average (12,SoilT\_5cm\_C,FP2,False)

Sample (12,SoilT2\_5cm\_C,FP2)  
Average (12,SoilT2\_5cm\_C,FP2,False)  
EndTable

\*\*\*\*\*

"" MAIN PROGRAM ""

\*\*\*\*\*

'SCAN (EXECUTE) PROGRAM AT 5-SEC INTERVALS

BeginProg

'Three-second scan interval

Scan (3,Sec,0,0)

"" Set Station ID ""

StationID = ID

' initialize the default (power up) conditions

If Initialized = 0 Then

  Initialized = 1

  NEWBATTCAP = 100 ' 100Ahr is max capacity the CH200 will accept

EndIf

'CS547A1 Conductivity and Temperature Probe #1 measurements Cond1\_mS\_cm,  
Cond1TC\_mS\_cm, and Cond1T\_C

'Make preliminary voltage measurement

BrFull(Rs1,1,mV2500,5,2,1,2500,True,True,0,250,-0.001,1)

'Convert voltage measurement to resistance

Rs1=Rs1/(1-Rs1)

'Make refined voltage measurement based on preliminary measurement

Select Case Rs1

Case Is <1.8

  BrHalf(Rs1,1,mV2500,10,2,1,2500,True,0,250,1,0)

Case Is <9.25

  BrFull(Rs1,1,mV2500,5,2,1,2500,True,True,0,250,-0.001,1)

Case Is <280

  BrFull(Rs1,1,mV250,5,2,1,2500,True,True,0,250,-0.001,1)

EndSelect

'Convert voltage measurement to resistance

Rs1=Rs1/(1-Rs1)

'Subtract resistance errors from cable length

Rs1=Rs1-(CS547A1cable\*0.000032+0.005)

'Calculate EC

```

Cond1_mS_cm=(1/Rs1)*CS547A1CalFactor
'Correct EC for ionization errors
If Cond1_mS_cm<0.474 Then
  Cond1_mS_cm=Cond1_mS_cm*0.95031-0.00378
Else
  Cond1_mS_cm=-0.02889+(0.98614*Cond1_mS_cm)+(0.02846*Cond1_mS_cm^2)
EndIf
'Make temperature measurement (Deg C)
Therm107(Cond1T_C,1,11,1,0,250,1,0)
'Correct EC for temperature errors
Cond1TC_mS_cm=(Cond1_mS_cm*100)/((Cond1T_C-25)*0+100)
'Trap measurements below 0.005 mS/cm threshold
If Cond1TC_mS_cm<0.005 Then Cond1TC_mS_cm=0.005

```

```

Cond1_uS_cm = Cond1_mS_cm * 1000
Cond1TC_uS_cm = Cond1TC_mS_cm * 1000

```

'CS547A2 Conductivity and Temperature Probe #2 measurements Cond\_mS\_cm, CondTC\_mS\_cm, and CondT\_C

```

'Make preliminary voltage measurement
BrFull(Rs2,1,mV2500,3,3,1,2500,True,True,0,250,-0.001,1)
'Convert voltage measurement to resistance
Rs2=Rs2/(1-Rs2)
'Make refined voltage measurement based on preliminary measurement
Select Case Rs2
Case Is <1.8
  BrHalf(Rs2,1,mV2500,6,3,1,2500,True,0,250,1,0)
Case Is <9.25
  BrFull(Rs2,1,mV2500,3,3,1,2500,True,True,0,250,-0.001,1)
Case Is <280
  BrFull(Rs2,1,mV250,3,3,1,2500,True,True,0,250,-0.001,1)
EndSelect
'Convert voltage measurement to resistance
Rs2=Rs2/(1-Rs2)
'Subtract resistance errors from cable length
Rs2=Rs2-(CS547A2cable*0.000032+0.005)
'Calculate EC
Cond2_mS_cm=(1/Rs2)*CS547A2CalFactor
'Correct EC for ionization errors
If Cond2_mS_cm<0.474 Then
  Cond2_mS_cm=Cond2_mS_cm*0.95031-0.00378
Else
  Cond2_mS_cm=-0.02889+(0.98614*Cond2_mS_cm)+(0.02846*Cond2_mS_cm^2)
EndIf
'Make temperature measurement (Deg C)
Therm107(Cond2T_C,1,7,1,0,250,1,0)

```



'Correct EC for temperature errors

Cond2TC\_mS\_cm=(Cond2\_mS\_cm\*100)/((Cond2T\_C-25)\*0+100)

'Trap measurements below 0.005 mS/cm threshold

If Cond2TC\_mS\_cm<0.005 Then Cond2TC\_mS\_cm=0.005

Cond2\_uS\_cm = Cond2\_mS\_cm \* 1000

Cond2TC\_uS\_cm = Cond2TC\_mS\_cm \* 1000

'Begin 60-sec Loop

If IfTime (0,60,Sec) Then

\*\*\*\*\* MEASURE DATALOGGER WIRING PANEL TEMPERATURE (deg C)  
PanelTemp (LoggerTemp\_C,250)

\*\*\*\*\* MEASURE DATALOGGER BATTERY VOLTS (V)  
Battery (BattVolts\_V)

' Feature to enter specific battery capacity as a Public value and send to charger(s)

'Get additional values from CH200

SDI12Recorder (CH200\_MX(),1,0,"M6!",1.0,0)

'If the present battery capacity isnot the same as the new battery capacity, send the new one.

If BattCap <> NEWBATTCAP Then

SDI12command = "XC" & FormatFloat (NEWBATTCAP, "%4.1f") & "!"

SDI12Recorder (SDI12result,1,0,SDI12command,1.0,0)

EndIf

\*\*\*\*\* CH200 CHARGE REGULATOR MEASUREMENTS  
SDI12Recorder (CH200\_M0(),1,0,"MC!",1.0,0)

' Compute running Power and daily running total AmpHours/Day values for each current measurement.

LoadPwr\_W = CH200BattVolts\_V \* LoadCrnt\_A

ChargePwr\_W = SolarPanel\_V \*SolarPanel\_A

' Divide each 1 minute Amp sample by 1440 sample/day so that the total at the end of the day is to get avg current for the day

' then muliply be 24 Hr/day to get AHr/Day. or divide by 60 because 24/1440 = 1/60

' Separate and sum each the positive and negative currents into and out of the battery to get the total AHr in/out for the day.

' Sample hourly and daily, then zero at end of the day.

If BattCrnt\_A > 0 Then DlyBatCrntIn\_AHr = DlyBatCrntIn\_AHr + BattCrnt\_A/60

If BattCrnt\_A < 0 Then DlyBatCrntOut\_AHr = DlyBatCrntOut\_AHr + BattCrnt\_A/60

\*\*\*\*\* READ INW or CSI SDI-12 Pressure Transducer  
SDI12Recorder (PT1Data(),5,1,"M!",1.0,0)

```

SDI12Recorder (PT2Data(),5,2,"M!",1.0,0
SDI12Recorder (PT3Data(),5,3,"M!",1.0,0
SDI12Recorder (PT4Data(),5,4,"M!",1.0,0
' convert water heights in psi to cm (70.307 cm/psi)
WaterHt1_cm = WaterHt1_psi * 70.307
'Convert Water Height in cm to ft. (0.0328 ft/cm)
WaterHt1_ft = WaterHt1_cm * 0.0328

```

```

WaterHt2_cm = WaterHt2_psi * 70.307
WaterHt2_ft = WaterHt2_cm * 0.0328
WaterHt3_cm = WaterHt3_psi * 70.307
WaterHt3_ft = WaterHt3_cm * 0.0328
WaterHt4_cm = WaterHt4_psi * 70.307
WaterHt4_ft = WaterHt4_cm * 0.0328

```

```

*****

```

```

" READ AM16/32 #1 MULTIPLEXER Every 1 minute "
```

```

*****

```

```

PortSet (2,1) 'TURN ON AM16/32 #1 MULTIPLEXER, SET PORT 2 HIGH

```

```

i = 1 'INITIALIZE INDEX INTERGER I TO ONE

```

```

'READ 36 GWS THERMISTORS

```

```

SubScan (0,Sec,4) 'SCAN LOOP -- 5 ITERATIONS

```

```

PulsePort (3,10000) 'ADVANCE AM16/32 #1 GROUP BY 1, PULSE PORT 2

```

```

'MEASURE GWS THERMISTORS, (Voltage Ratio X = Rs/(Rs+Rf))

```

```

BrHalf (therm(i),1,mV2500,1,Vx1,1,2500,True ,0,_60Hz,1.0,0)

```

```

i = i + 1

```

```

BrHalf (therm(i),1,mV2500,2,Vx1,1,2500,True ,0,_60Hz,1.0,0)

```

```

i = i + 1

```

```

BrHalf (therm(i),1,mV2500,3,Vx1,1,2500,True ,0,_60Hz,1.0,0)

```

```

i = i + 1

```

```

NextSubScan

```

```

PortSet (2,0) 'TURN OFF AM16/32 #1 MULTIPLEXER, SET PORT 1 LOW

```

```

'CONVERT MEASURED VOLTAGE RATIO TO RESISTANCE (kOHM) FOR 36 GWS
THERMISTORS

```

```

For i=1 To 12

```

```

Therm_kOhm(i) = Rf*therm(i)/(1-therm(i))

```

```

Next i

```

```

'CONVERT GWS THERMISTOR RESISTANCE TO deg C FOR 36 GWS

```

```

THERMISTORS

```

```

For i=1 To 12

```

```

D(i) = LN (1000*Therm_kOhm(i)) 'ln resistance (ohm)

```

```

Temp_C(i) = (1/(a + b*D(i) + c*(D(i))^3)) - 273.15 'Steinhart & Hart Equation

```

```

Next i

```

```
EndIf 'End of 60-second scan loop

CallTable HourlyDiag
CallTable QuarterHourlyWater
CallTable HourlyRaw
CallTable Daily
CallTable HrlyClimate
CallTable HourlySubs

If IfTime (0,1440,Min) Then
  DlyBatCrtIn_AHr = 0
  DlyBatCrtOut_AHr = 0
EndIf

NextScan
EndProg
```

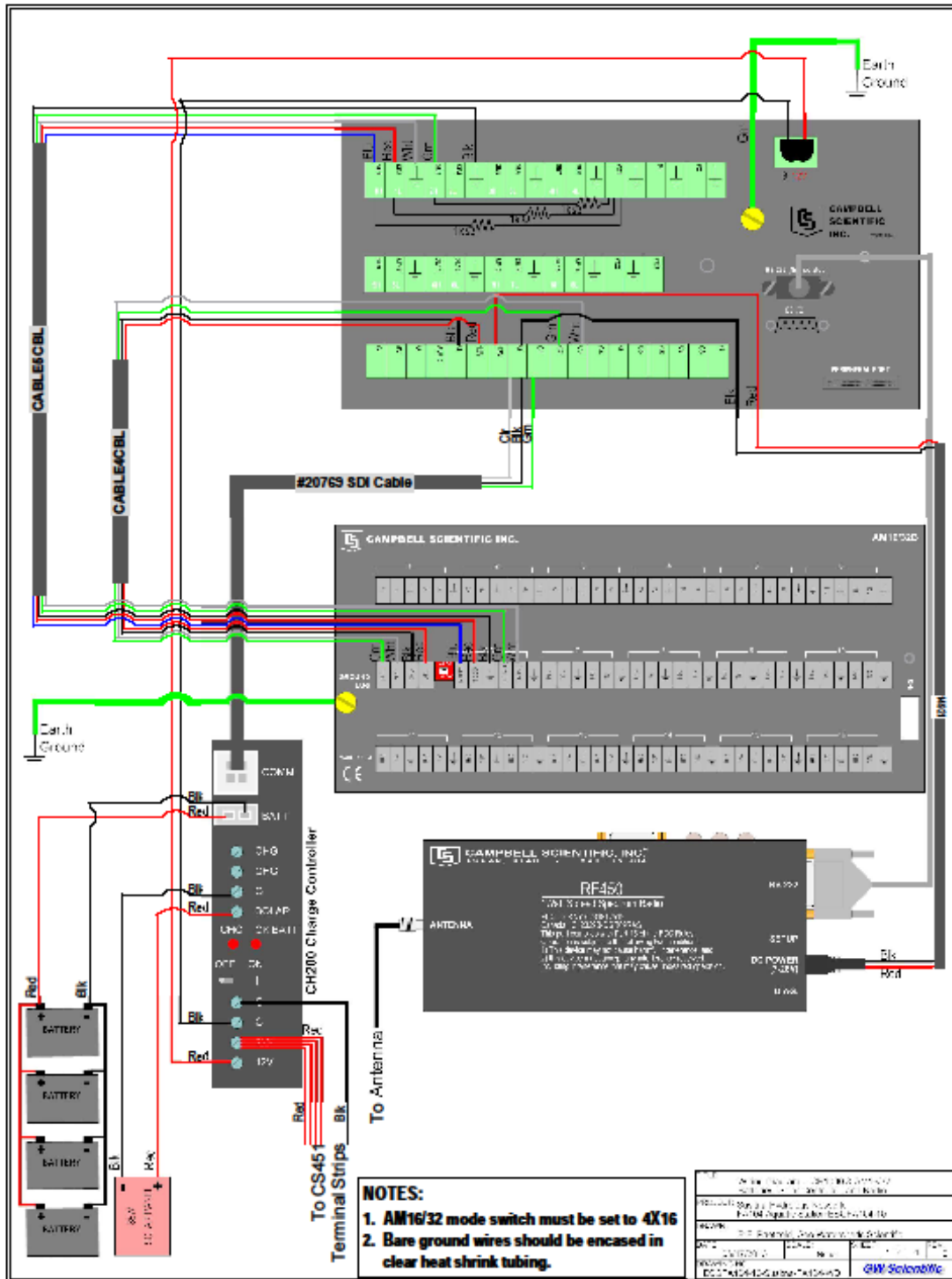


Figure C-19. ESGFA104-10 Sheet 1 (Data Logger, Power, Radio, Multiplexer).





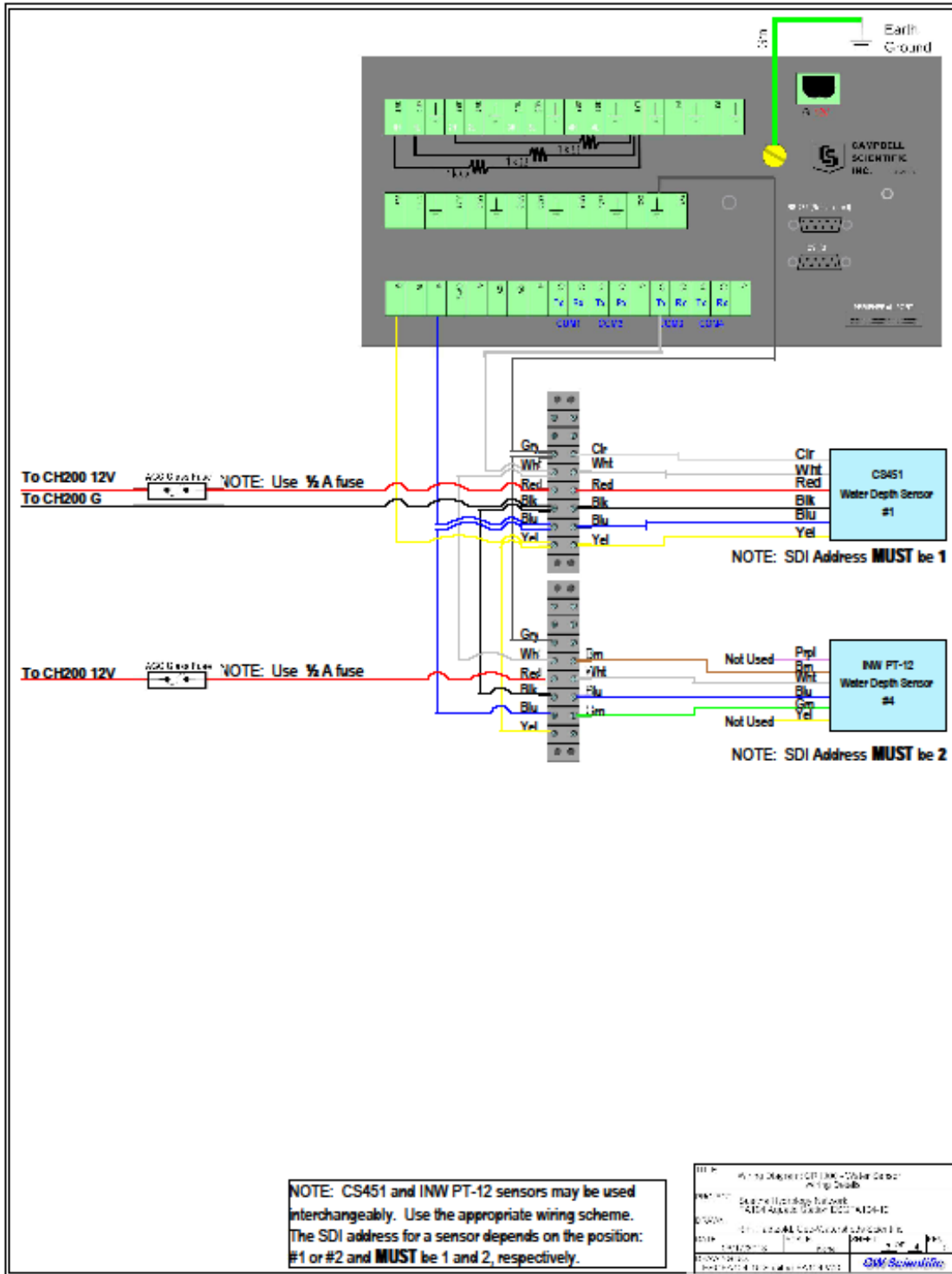


Figure C-22. ESGFA104-10 Sheet 3Alt (Data Logger, Mix CS451 & INW PT-12 WaterSensors).

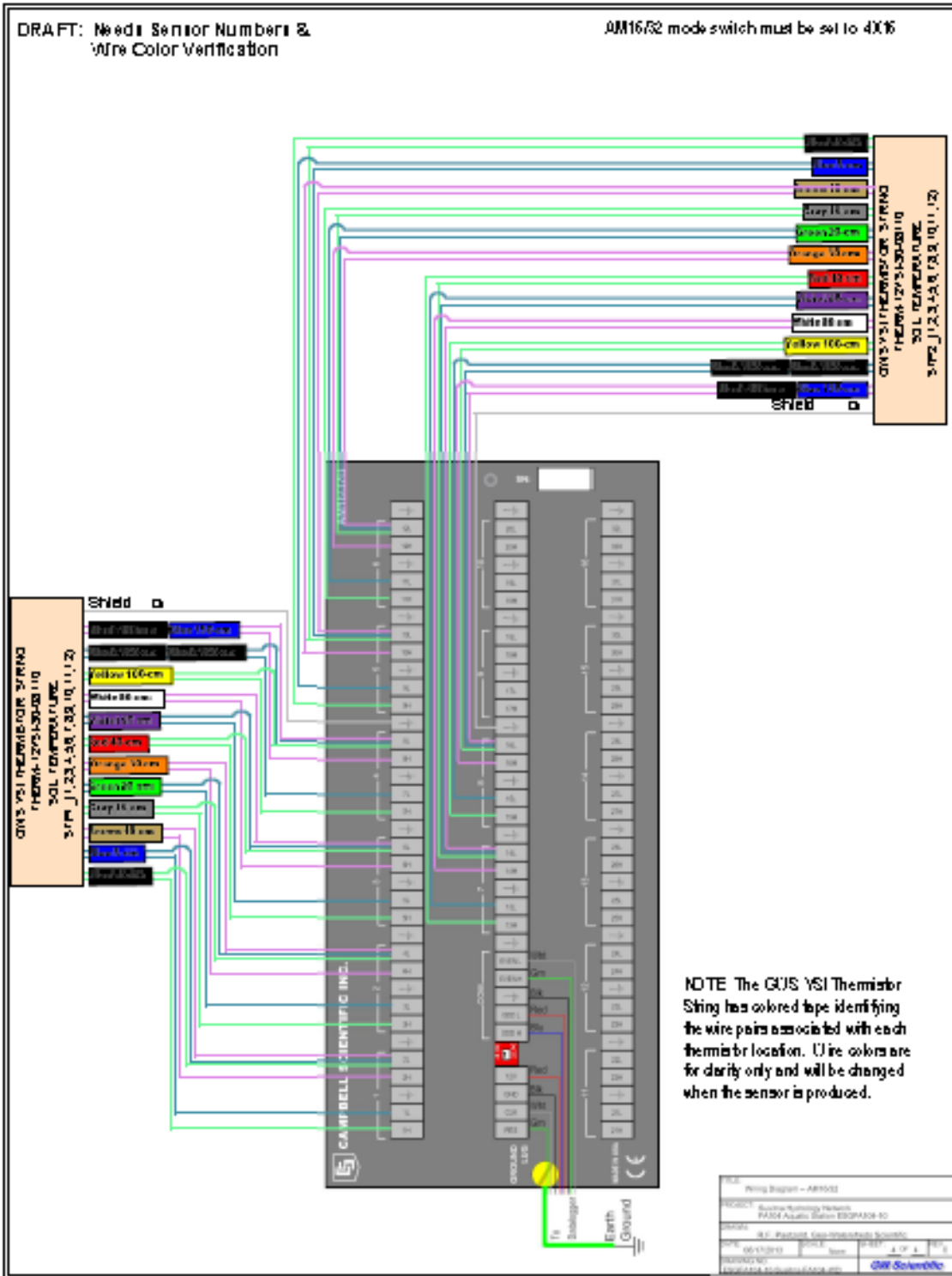


Figure C-23. ESFA104-10 Sheet 4 (Multiplexer, Sensors).



**Susitna-Watana Hydroelectric Project  
(FERC No. 14241)**

**Groundwater Study (7.5)**

**Appendix D  
Selected Focus Area Time-Lapse Photo Examples**

**Initial Study Report**

Prepared for

Alaska Energy Authority



**SUSITNA-WATANA HYDRO**

*Clean, reliable energy for the next 100 years.*

Prepared by

Geo-Watersheds Scientific

February 2014 Draft

## APPENDIX D: SELECTED FOCUS AREA TIME-LAPSE PHOTO EXAMPLES

The selected images in this appendix are intended to show a range of applications for each camera station. The primary purpose of each camera station may vary, but all cameras were in positions to help gain the most information for a variety of study objectives. Cameras with a view of water bodies are applicable for the groundwater/surface-water interactions and for use with other forms of empirical data being collected. All cameras also help capture important riparian vegetation changes in a wide assortment of vegetation units. For example, riparian evapo-transpiration porometer protocol requires specific atmospheric (cloudy or full sun) and dry leaf conditions for conducting leaf porometer measurements. Near-real-time photos allow scheduling of field trips during appropriate atmospheric conditions, therefore facilitating cost-effective field operation. Cameras have also captured ice / floodplain vegetation interactions, informing the floodplain vegetation ice processes study design.

Images from all but two cameras are manually downloaded when field crews are working in a Focus Area, so each set of available images may vary in number of available images and date ranges. The other two cameras are part of the Campbell Scientific CR1000 data acquisition system reporting over the radio telemetry network and provide images in near-real-time. Because poor images may still provide some useful information, only images with no clear view are deleted during quality control checks. Examples of these conditions include camera lens covered in frost or snow, tree limbs completely blocking the camera view, or general camera malfunctions.

**Table D-1. This table lists example QC3 Focus Area time-lapse station images. Following the table, example images are provided below in downstream Focus Area order.**

Stations Equipped with Time-Lapse Images	Site	Camera Installation Date	Last Image Download Date	Number of Images Currently Available
FA-138 (Gold Creek)	ESCFA138-8 <sup>2</sup>	2013-11-06	2013-11-06	1
	ESCFA138-9	2013-11-06	2013-11-17	445
	ESCFA138-10	2013-11-06	2013-11-17	723
	ESCFA138-11 <sup>2</sup>	2013-11-06	2013-11-06	1
FA-128 (Slough 8A)	ESSFA128-1 <sup>1</sup>	2013-05-13	2014-01-14	8393
	ESCFA128-29	2013-11-06	2013-11-22	2449
	ESCFA128-30	2013-10-04	2013-11-22	1038
	ESCFA128-31	2013-10-25	2013-11-09	1457
	ESCFA128-32 <sup>2</sup>	2013-10-25	2013-10-25	1
	ESCFA128-34 <sup>2</sup>	2013-11-03	2013-11-03	1
	ESCFA128-35	2013-11-06	2013-11-21	1396
FA-115 (Slough 6A)	ESCFA128-36 <sup>3</sup>	2013-11-03	not available	0
	ESCFA115-11 <sup>2</sup>	2013-11-03	2013-11-03	1
	ESCFA115-12 <sup>2</sup>	2013-11-03	2013-11-03	1
FA-113 (Oxbow 1)	ESCFA115-13 <sup>2</sup>	2013-11-03	2013-11-03	1
	ESCFA113-2 <sup>2</sup>	2013-11-02	2013-11-02	1
	ESCFA113-3 <sup>2</sup>	2013-10-31	2013-10-31	1
FA-104 (Whiskers Slough)	ESCFA113-4 <sup>2</sup>	2013-10-31	2013-10-31	1
	ESSFA104-1	2013-04-20	2014-01-14	2436
	ESCFA104-16	2013-10-31	2013-12-04	1424
	ESCFA104-17	2013-10-31	2013-12-09	2155
	ESCFA104-18 <sup>2</sup>	2013-10-31	2013-10-31	1
	ESCFA104-19	2013-10-31	2013-11-13	1232
	ESCFA104-20	2013-10-31	2013-11-15	1429
	ESCFA104-21 <sup>3</sup>	2013-10-31	not available	0
ESCFA104-22	2013-10-31	2013-12-09	2590	

<sup>1</sup> Campbell Scientific 5MPX near-real-time reporting camera

<sup>2</sup> The single image provided is the first image taken upon installation of this camera. Additional images will be retrieved during the next site visit.

<sup>3</sup> Images will be retrieved during the next site visit.



**Figure D-1.** This FA-138 (Gold Creek) image from ESCFA138-8 displays a view of early-winter river side channel and Slough 11 conditions on November 06, 2013. Station camera records images (empirical data) for the Slough 11 outlet conditions, leaf-out and leaf-off timing, and winter ice and snow cover conditions.



**Figure D-2.** This FA-138 (Gold Creek) image from ESCFA138-9 displays a view of early winter Slough 11 conditions on November 06, 2013. Station camera records images (empirical data) for the Slough 11 aquatic transect, Slough 11 hydrology conditions, leaf-out and leaf-off timing, and winter ice and snow cover conditions.





Figure D-3. This FA-138 (Gold Creek) image from ESCFA138-10 displays an early winter view of Upper Side Channel 11, with the main channel in the background on November 06, 2013. Station camera records images (empirical data) for the Upper Side Channel 11 aquatic transect, outlet hydrology conditions, main channel in the background, leaf-out and leaf-off timing, riparian vegetation / ice interactions, and winter ice and snow cover conditions.



Figure D-4. This FA-138 (Gold Creek) image from ESCFA138-11 displays a view of early winter main channel river conditions on November 06, 2013. The station image is looking upstream. Station camera records images (empirical data) for the FA-138 riparian transect, main channel hydrology, leaf-out and leaf-off timing, riparian vegetation / ice interactions, and winter ice and snow cover conditions.



**Figure D-5.** These FA-128 (Slough 8A) images from ESSFA128-1 display spring snowmelt flooding through Slough 8A and side channel on May 29, 2013 (top) and summer water-quality differences between Slough 8A and inflow from the side channel on June 04, 2013 (bottom). Station camera records images (empirical data) for the side channel, slough, leaf-out and leaf-off timing, riparian vegetation / ice interactions, winter ice and snow cover conditions. This camera is part of the Campbell Scientific CR1000 data acquisition system reporting over the radio telemetry network and provides images in near-real-time



Figure D-6. These FA-128 (Slough 8A) images from ESCFA128-29 displays a side channel on the left hand side of the image view and a junction at the top of the side channel leading down to Slough 8a on the right. The top image was taken in early winter on November 06, 2013. The bottom picture was taken during winter conditions on November 22, 2013. Station camera records images (empirical data) for the inlet and outlet, side channel, leaf-out and leaf-off timing, riparian vegetation / ice interactions, and winter ice and snow cover conditions.





Bushnell

10-04-2013 16:15:58



Bushnell

11-09-2013 15:14:07

Figure D-7. These FA-128 (Slough 8A) images from ESCFA128-30 display the upstream end of Slough 8A in late fall conditions on October 04, 2013 (top) and early winter conditions on November 09, 2013 (bottom). Station camera records images (empirical data) for the slough, leaf-out and leaf-off timing, riparian vegetation / ice interactions, and winter ice and snow cover conditions. The image direction is looking upstream.





Figure D-8. These FA-128 (Slough 8A) images from ESCFA128-31 display the location of the Slough 8A upper aquatic transect near ESGFA128-7 in late fall on October 25, 2013 (top) and early winter conditions on November 09, 2013 (bottom). Station camera records images (empirical data) for the aquatic transect, slough and stream, leaf-out and leaf-off timing, riparian vegetation / ice interactions, and winter ice and snow cover conditions. The image direction is looking upstream.



Bushnell

10-25-2013 15:50:58

Figure D-9. This FA-128 (Slough 8A) image from ESCFA128-32 displays the upper riparian transect and station ESCFA128-5 with trees instrumented with sap flow sensors in late fall conditions on October 10, 2013. Station camera records images (empirical data) for the riparian transect and leaf-out and leaf-off timing.



Figure D-10. This FA-128 (Slough 8A) image from ESCFA128-34 displays a side channel with an inlet to an additional side channel on the right side of the picture on November 03, 2013. Station camera records images (empirical data) for the riparian transect, inlet and outlet, main channel, side channel, riparian vegetation / ice interactions, and leaf-out and leaf-off timing.



Figure D-11. This FA-128 (Slough 8A) image from ESCFA128-36 displays a view looking at a side channel downstream of the outlet of Slough 8A on November 03, 2013. Station camera records images (empirical data) for the outlet, side channel, stream, leaf-out and leaf-off timing, riparian vegetation / ice interactions, and winter ice and snow cover conditions.





Bushnell

11-03-2013 14:12:39

Figure D-12. This FA-115 (Slough 6A) image from ESCFA115-11 displays an unnamed stream recharged by groundwater near ESGFA115-2 in early winter on November 03, 2013. Station camera records images (empirical data) for the riparian transect, stream, leaf-out and leaf-off timing, riparian vegetation / ice interactions, and winter ice and snow cover conditions.



Bushnell

11-03-2013 13:43:56

Figure D-13. This FA-115 (Slough 6A) image from ESCFA115-12 displays a view of a side channel, looking downstream on November 03, 2013. Station camera records images (empirical data) for the riparian transect, side channel, leaf-out and leaf-off timing, and winter ice and snow cover conditions.



Figure D-14. This FA-115 (Slough 6A) image from ESCFA115-13 displays Slough 6A and the outlet of the unnamed stream flowing into the slough on November 02, 2013. Station camera records images (empirical data) for the slough and stream, leaf-out and leaf-off timing, riparian vegetation / ice interactions, and winter ice and snow cover conditions.



Figure D-15. This FA-113 (Oxbow 1) image from ESCFA113-2 displays the inlet to the Oxbow 1 side channel, looking across the mainstem channel on November 02, 2013. Station camera records images (empirical data) for the inlet, main channel, side channel, leaf-out and leaf-off timing, riparian vegetation / ice interactions, and winter ice and snow cover conditions.





Bushnell

10-31-2013 15:34:01

Figure D-16. This FA-113 (Oxbow 1) image from ESCFA113-3 displays the outlet of the Oxbow 1 side channel with the mainstem channel in the background, looking downstream on October 31, 2013. Station camera records images (empirical data) for the outlet, main channel, side channel, leaf-out and leaf-off timing, riparian vegetation / ice interactions, and winter ice and snow cover conditions.



Bushnell

10-31-2013 15:54:12

Figure D-17. This FA-113 (Oxbow 1) image from ESCFA113-4 displays a view looking at the Oxbow 1 side channel and unnamed stream flowing into the major bend in the side channel at the ESGFA113-1 station location on October 31, 2013. Station camera records images (empirical data) for the aquatic transect, side channel, slough and stream, leaf-out and leaf-off timing, riparian vegetation / ice interactions, and winter ice and snow cover conditions.

2013/06/05 10:00:06 SUSITNA RIVER FOCUS AREA 1 View1



2013/06/10 03:00:17 SUSITNA RIVER FOCUS AREA 1 View1



**Figure D-18.** These FA-104 (Whiskers Creek) images from ESSFA104-1 display vegetation development and the confluence of Whiskers Slough and Whiskers Creek, looking upstream during leaf-out on June 05, 2013 (top) and on June 10, 2013 (bottom). Station camera records images (empirical data) for the inlet and outlet, slough, leaf-out and leaf-off timing, riparian vegetation / ice interactions, and winter ice and snow cover conditions. This camera is part of the Campbell Scientific CR1000 data acquisition system reporting over the radio telemetry network and provides images in near-real-time.





Bushnell

10-31-2013 15:16:26



Bushnell

11-22-2013 11:30:44

Figure D-19. These FA-104 (Whiskers Slough) images from ESCFA104-16 display the outlet of Whiskers Slough and side channel in the background, looking downstream in early winter on October 31, 2013 (top) and during early winter ice jamming on November 22, 2013 (bottom). Station camera records images (empirical data) for the outlet, slough and stream, leaf-out and leaf-off timing, riparian vegetation / ice interactions, and winter ice and snow cover conditions.





Bushnell

10-31-2013 11:30:30



Bushnell

12-04-2013 14:15:23

**Figure D-20.** These FA-104 (Whiskers Slough) images from ESCFA104-17 displays Whiskers Creek, just above the confluence with Whiskers Slough, looking downstream in late fall conditions on October 31, 2013 (top) and after initial early winter ice jamming on the mainstem on December 04, 2013 (bottom). Station camera records images (empirical data) for the slough and stream, leaf-out and leaf-off timing, riparian vegetation / ice interactions, and winter ice and snow cover conditions.



Bushnell

10-31-2013 12:07:45

**Figure D-21.** This FA-104 (Whiskers Slough) image from ESCFA104-18 displays Whiskers Creek, looking downstream during late fall conditions on October 31, 2013. Station camera records images (empirical data) for the stream, leaf-out and leaf-off timing, riparian vegetation / ice interactions, and winter ice and snow cover conditions.



Bushnell

10-31-2013 12:54:41



Bushnell

11-12-2013 13:00:38

**Figure D-22.** These FA-104 (Whiskers Slough) images from ESCFA104-19 display an outlet/inlet of Whiskers Slough and Whiskers Side Channel, looking across and upstream at the mainstem channel in late fall on October 31, 2013 (top) and in early winter before mainstem ice jamming on November 12, 2013 (bottom). Station camera records images (empirical data) for the inlet/outlet, side channel, slough and stream, leaf-out and leaf-off timing, riparian vegetation / ice interactions, and winter ice and snow cover conditions.





Bushnell

10-31-2013 15:20:26



Bushnell

11-15-2013 11:34:47

**Figure D-23.** These FA-104 (Whiskers Slough) images from ESCFA104-20 display the Whiskers Side Channel, looking downstream, at the upper outlet to Whiskers Slough, in the Slough 3A reach, in late fall on October 31, 2013 (top) and in early winter on November 15, 2013 (bottom). The mainstem has not yet developed early winter ice jams. Station camera records images (empirical data) for the side channel, leaf-out and leaf-off timing, riparian vegetation / ice interactions, and winter ice and snow cover conditions.



Bushnell

10-31-2013 01:53:01



Bushnell

11-15-2013 10:47:39

**Figure D-24.** These FA-104 (Whiskers Slough) images from ESCFA104-21 display a view looking upstream at the upstream end of Whiskers Side Channel at the ESGFA104-10 station location during late fall on October 31, 2013 (top). The bottom image shows early winter conditions on November 15, 2013. The mainstem has not yet developed early winter ice jams. Station camera records images (empirical data) for the aquatic transect, main channel, side channel, leaf-out and leaf-off timing, riparian vegetation / ice interactions, and winter ice and snow cover conditions.





Bushnell

10-31-2013 01:20:03



Bushnell

11-14-2013 12:10:28

Figure D-25. These FA-104 (Whiskers Slough) images from ESCFA104-22 display a view looking across the inlet/outlet of Whiskers Slough, in the Slough 3B reach, and across the Whiskers Side Channel on October 31, 2013 (top). The bottom image shows early winter conditions on November 4, 2013. The mainstem has not yet developed early winter ice jams. Station camera records images (empirical data) for the inlet/outlet, side channel, slough, leaf-out and leaf-off timing, riparian vegetation / ice interactions, and winter ice and snow cover conditions.

**Susitna-Watana Hydroelectric Project  
(FERC No. 14241)**

**Groundwater Study (7.5)**

**Appendix E  
Level-Loop Survey and Survey Control Points  
Examples**

**Initial Study Report**

Prepared for

Alaska Energy Authority



**SUSITNA-WATANA HYDRO**

*Clean, reliable energy for the next 100 years.*

Prepared by

Geo-Watersheds Scientific

February 2014 Draft

## APPENDIX E: LEVEL-LOOP SURVEY AND SURVEY CONTROL POINTS EXAMPLES

The establishment and maintenance of survey control for hydrologic stations is important when conducting hydrology studies. Multi-year studies require elevations control networks that are accessible in summer and winter and maintain continuity of data accuracy over the multi-year study period. This becomes more critical when groundwater/surface-water (GW/SW) interaction studies are being conducted. Horizontal and vertical GW/SW gradients may frequently reverse direction (transient interactions), resulting in periods with very flat gradients. As hydrologic gradients become more flat, survey error can significantly change interpretations of the direction and rate of groundwater flow, and exchanges with surface-water systems.

For this reason, horizontal and vertical survey control points were established using the methods described in the Instream Flow Study (Section 8.5.4.1.1). The selected level-loop vertical elevation surveys in this appendix provide an example of standardized QA/QC protocol for measuring elevations with level-loop survey methods established for the Groundwater Study. Level-loop surveys are conducted to measure water surface elevation and track water level changes over time and to establish survey control. Examples of the F-001 Elevation Survey Form have been provided, showing forms that have reached the status of quality control level 3 (QC3), the QC level at which data are reviewed by a Project team senior professional, checking for logic, soundness, and adding qualifiers to results if warranted. A photo image of a survey underway during a well installation to measure water levels to Project datum and accuracy standards is also included.

Images of temporary benchmark (TBM) control points are displayed following the provided examples of level-loop vertical elevation survey forms. Typically, three to four benchmarks are used for an elevation control network at a groundwater or surface-water station. These benchmarks ensure consistency and accuracy when level-loop surveys are conducted. This is a more accurate method than using RTK surveying methods each year. The primary benefit of the RTK surveying is the efficient initial establishment of Project datum at a local site in reference to area-wide control networks. An excerpt of example control point coordinate data is included in the last figure. The combination of these survey techniques provides a defensible approach to surveying hydrology stations and features in arctic environments.





**Figure E-1. This image taken at FA104 (Whiskers Slough) depicts a survey underway during a well installation to measure water levels to Project datum and accuracy standards on August 27, 2013.**











**Figure E-5. This figure depicts example survey control points established at FA-128 (Slough 8A) for conducting level-loop vertical elevation surveys.** The top images illustrate elevation survey temporary benchmarks (TBM) located on trees. The top right image displays TBM 2 at ESGFA128-13. The bottom image displays an aluminum cap (Alcap) on rebar (TBM1) at ESGFA128-20. It is common for rebar TBMs to frost heave in winter, so it is beneficial to use 3 to 4 points in trees or other solid features. TBMs also have to be found in the winter, which becomes difficult when there is 3 to 6 feet of snow on the ground.

<b>Groundwater Study</b>						
Control Point Coordinates RTK						
Date of Survey: August 2013						
Lead Technical Contact:		Steve Smith, Geovera, scsmith@gci.net, 907-399-4345				
Last Update:		8/19/13				
Last Update By:		Steve Smith				
The following data is Final DRAFT						
Horizontal data is WGS84/AKSP Zone 4 U.S. Survey Feet, Vertical data is NAVD88/Geoid09 (Feet)						
<b>Focus Area 104</b>						
Groundwater Study Control Points						
Point No.	Latitude	Longitude	Northing	Easting	Elevation	Descriptor
30418	62.3744469920	150.1683474340	3059916.9590	1611834.7670	376.97	WS-10 TBM 10
30419	62.3744480610	150.1683481590	3059917.3500	1611834.6450	376.88	WS-10 MW1 OG
30420	62.3761950050	150.1696798130	3060556.6530	1611610.2340	377.73	ESGFA104-9 MW4 OG
30421	62.3762172670	150.1699588940	3060564.9170	1611562.8760	373.96	ESGFA104-9 W3 OG
30422	62.3762850540	150.1705566030	3060589.9680	1611461.4690	373.04	ESGFA104-9 W2 OG
30423	62.3762860130	150.1709339520	3060590.4880	1611397.4080	380.10	ESGFA104-9 W1 OG
30424	62.3762572150	150.1709094430	3060579.9480	1611401.5410	381.17	ESGFA104-9 SITE OG
30425	62.3761894270	150.1707793630	3060555.1050	1611423.5590	380.03	ESGFA104-9 TBM1
30427	62.3768392480	150.1696435520	3060792.1830	1611617.0080	378.69	ESGFA104-1 TBM10
30428	62.3767573610	150.1693425750	3060762.1100	1611668.0250	377.12	ESGFA104-1 SITE OG
30429	62.3768034340	150.1697220640	3060779.1240	1611603.6450	377.46	ESGFA104-1 TOP BANK
30431	62.3769993660	150.1701461570	3060850.9490	1611531.8370	374.82	WS-30 OG
30432	62.3768812060	150.1713599770	3060808.2920	1611325.6590	375.57	WC 10 TBM10
30433	62.3768417120	150.1714261430	3060793.8820	1611314.3880	374.81	WC 10 OG
30435	62.3781707000	150.1701921040	3061279.2290	1611525.1640	377.08	ESGFA104-5 TBM4
30436	62.3780994890	150.1703813870	3061253.2780	1611492.9630	377.27	ESGFA104-5 MW1 OG
30437	62.3781003030	150.1702863570	3061253.5330	1611509.0960	378.87	ESGFA104-5 SITE OG
30438	62.3780629040	150.1701647780	3061239.8050	1611529.6990	375.61	ESGFA104-5 TOP BANK 1
30439	62.3781660290	150.1705874170	3061277.6980	1611458.0520	374.20	ESGFA104-5 TOP BANK 2
30440	62.3782369420	150.1709999130	3061303.8100	1611388.0960	376.81	ESGFA104-13 TBM10
30441	62.3786350080	150.1718091300	3061449.7140	1611251.1120	379.86	ESMFA104-2 TBM10
30442	62.3786267210	150.1719039900	3061446.7270	1611235.0010	379.57	ESMFA104-2 SITE OG
30443	62.3787823630	150.1721401330	3061503.7390	1611195.0660	379.45	ESMFA104-2 MW1 OG

Figure E-6. An example of RTK control point coordinates compiled and updated in August 2013.